

# OSI SUBMETERING WATT/WATTHOUR AC TRANSDUCER MODEL WL50-

## DESCRIPTION

The WL50 series of transducers provides a relay output with a pulse rate proportional to measured energy consumption (kWh). An optional analog output signal proportional to Watts is also available. High-accuracy, split-core, current transformers are supplied with the transducers in current ranges up to 500 Amps. These transformers provide a voltage-limited secondary that eliminates the shock hazard normally associated with open-secondary leads. All transducers are self-powered from the circuit being measured. Voltages up to 480 Volts can be directly connected to appropriately-rated transducers. Rugged metal enclosures, small size, and split-core transformers make the WL50 ideal for retrofit or initial installations in sub-metering or building management applications.

Six diagnostic LED lamps are provided to assist in verification of installation. These LEDs will indicate phase sequence errors, missing phase, CT polarity reversal, etc. An additional LED indicates relay operation. Refer to Installation Diagnostics for more information.

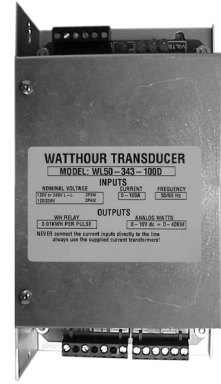

System Configuration	AC Volts Nominal	AC Amps	Model Number WL50-	F.S. Input	kWh/Pulse*
1-Phase 2-Wire (1-element)	120 L-N 240 L-N	0 - 0.1	123	24W	0.0001**
		0 - 50	123-050	12kW	0.01
		0 - 100	123-100	24kW	0.01
		0 - 200	123-200	48kW	0.01
		0 - 500	123-500	120kW	0.1
1-Phase 3-Wire (2-element)	120 L-N (240 L-L)	0 - 0.1	133	24W	0.0001**
		0 - 50	133-050	12kW	0.01
		0 - 100	133-100	24kW	0.01
		0 - 200	133-200	48kW	0.01
		0 - 500	133-500	120kW	0.1
3-Phase 3- or 4-Wire (3-element)	120 L-L 240 L-L 120/208	0 - 0.1	343	42W	0.0001**
		0 - 50	343-050	21kW	0.01
		0 - 100	343-100	42kW	0.01
		0 - 200	343-200	84kW	0.01
		0 - 500	343-500	210kW	0.1
3-Phase 3- or 4-Wire (3-element)	480 L-L 277/480	0 - 0.1	346	84W	0.0001**
		0 - 50	346-050	42kW	0.01
		0 - 100	346-100	84kW	0.01
		0 - 200	346-200	168kW	0.01
		0 - 500	346-500	420kW	0.1

## FEATURES

- Low Cost
- Split-Core Current Transformers
- Analog Output Option
- Small Package
- Diagnostic Indicators
- Accuracy - Meets ANSI C12.1

## APPLICATIONS

- Sub-metering
- Building Management

**5 YEAR WARRANTY**

## ORDERING INFORMATION

Example: 480V L-L, 200A, 3Φ, 3W with  
10ft. CT Leads  
**WL50-346-200L**

0.1A models are supplied without CTs. See CTY-xxxx.1 listing for available types.

Analog Watt Output Options:

- 0-1mAdc - add suffix B to model number
- 0-10Vdc - add suffix D to model number
- 0-5Vdc - add suffix X5 to model number
- 4-20mAdc - add suffix E to model number
- KYZ relay option - add suffix K to model number
- 10ft CT Leads - add suffix L to model number

\*kWh per each contact operation

\*\* To calculate the pulse scaling with different current transformer ratios multiply the CT ratio by 0.0001kWh.  
Example: To use 100:0.1 ratio CTs  
Ratio = 100/0.1 = 1000  
1000 \* 0.0001kWh = 0.1kWh per pulse

## SPECIFICATIONS

### INPUT

Voltage..... See Table  
Measurement Range ..... ±20% of nominal input  
Over-range ..... 150V, 300V, or 600V depending on model  
Current..... See Table  
Over-range ..... 150% of range  
Frequency ..... 50/60Hz  
Power Factor..... 0.5 Lead to 0.5 Lag  
Burden  
Voltage ..... 0.4VA max.  
Instrument Power ..... 2.5VA max.

### DIELECTRIC TEST

Input/Output/Case..... 1500Vac

### TEMPERATURE

Temperature Effect..... (0 - +50°C)..... ±0.03%/°C

### OUTPUT

kWh Pulse..... Type ..... Form A, Solid-State Contact  
120V, 0.3A, 10VA max.  
Scaling ..... See Table  
Contact Closure Duration..... 200ms  
Optional Analog Watt Output:  
Loading  
0-1mAdc models..... ≤10kΩ  
0-5Vdc, 0-10Vdc models ..... ≥2kΩ  
4-20mAdc models..... ≤500Ω

**ACCURACY** ..... ±0.5% F.S.  
Includes linearity, setpoint, power factor & current sensor.

### PHYSICAL

Net Weight ..... 2.0 lbs  
Termination ..... 14 AWG max.

**OHIO SEMITRONICS, INC.** 4242 REYNOLDS DRIVE \* HILLIARD, OHIO \* 43026-1264  
PHONE: (614) 777-1005 \* FAX: (614) 777-4511  
WWW.OHIOSEMITRONICS.COM \* 1-800-537-6732

## CASE DIMENSIONS

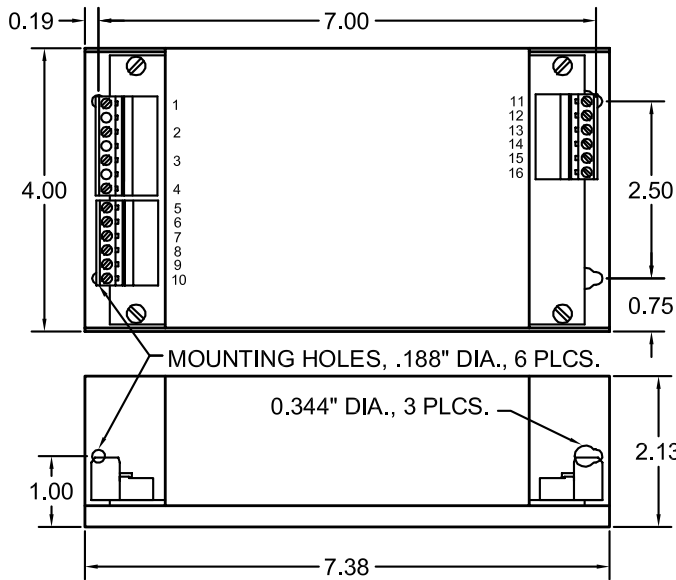

## TRANSFORMER DIMENSIONS

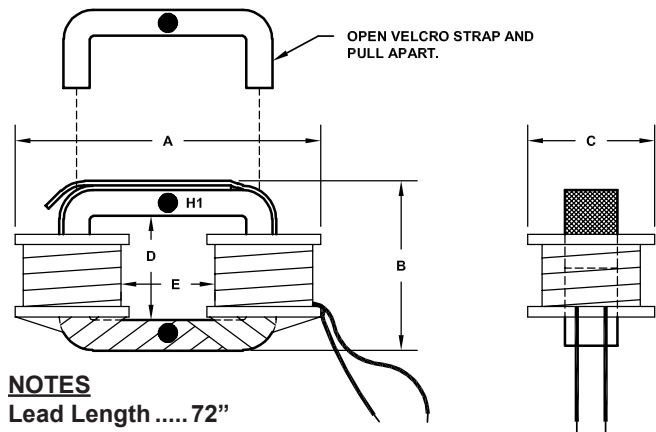

**NOTES**  
 Lead Length ..... 72"  
 Option "L" ..... 120"

CURRENT RATING	A	B	C	D	E
50A thru 100A	2.80	2.00	1.12	0.90	0.85
200A thru 500A	3.85	3.80	1.30	2.40	1.25

All dimensions in inches

## INSTALLATION DIAGNOSTICS

The WL50 has a set of 7 Light Emitting Diodes (LEDs) to aid in diagnosing problems with connections. There are 3 green LEDs for voltage, 3 red LEDs for current, and one red LED for load rate indication. LED indications are as follows:

### CURRENT DIAGNOSTICS (assuming proper operating voltage)

CURRENT (RED LED)	Good CT Connection	CT Reversed	No Load Current
Φ 1	On	Off Blink On	Off
Φ 2	On	Off Blink On	Off
Φ 3	On	Off Blink On	Off

### LOAD RATE INDICATOR:

Red LED will light for duration of contact closure (200 milliseconds standard) and at the same rate as described in model number chart.

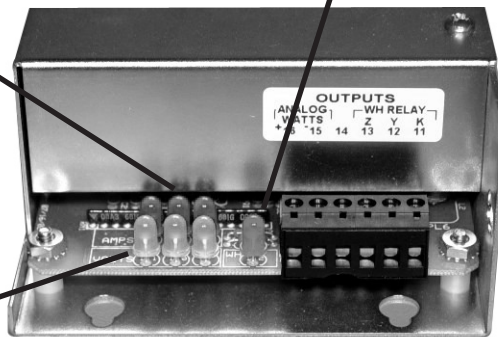

### VOLTAGE DIAGNOSTICS:

VOLTAGE (GREEN LED)	Voltage > 266V L-N (460V L-L)	265 L-N > Volts > 177 L-N (459V L-L) (306V L-L)	176 L-N > Volts > 85 L-N (305V L-L) (147V L-L)	Low or Missing Voltage Volts < 85 L-N (145V L-L)
Φ 1	On	On Blink Off	Off Blink On	Off
Φ 2	On	On Blink Off	Off Blink On	Off
Φ 3	On	On Blink Off	Off Blink On	Off

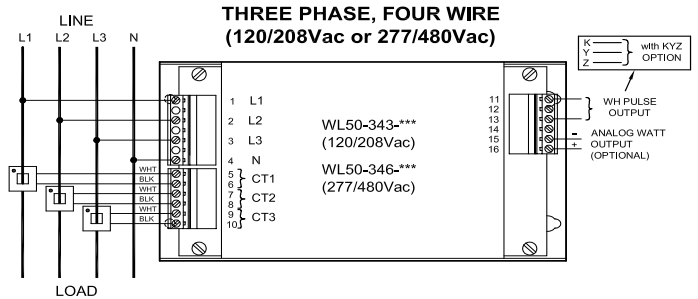
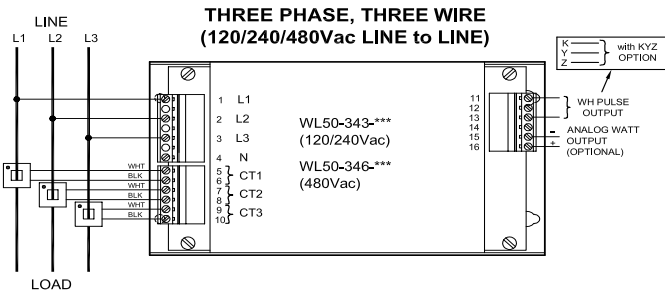
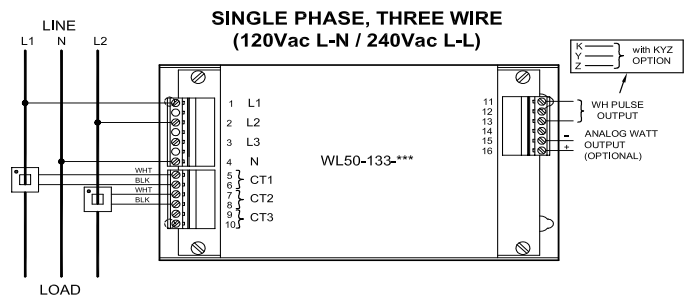
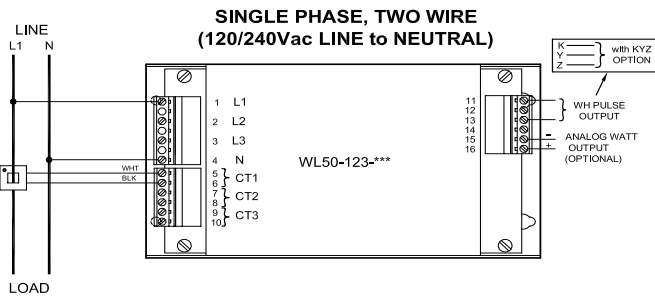

## NOTES

### CAUTION

To prevent damage to power lines, transducer, or personnel, **NEVER** connect current inputs directly to the line.

Use CTY-xxx.1 current transformers which may be supplied with the unit or purchased separately.

**DO NOT** unplug the CT1, CT2, CT3 terminal block while CTs are connected to a live circuit.