

USB - Torque Sensor with Configuration and Evaluation Software**DR-3001**

- Nominal torque from 0.1 N·m ... 5000 N·m
- High accuracy 0.1% f. scale
- Up to 2500 Measurements/s
- Feed-in from USB, without ext. power supply
- Very short axial length
- Reliable and durable
- Special versions on request
- Suited for mobile operation with a notebook
- Calibration parameter lodged in sensor
- Calibration control actuation by software
- Integrated speed/angle measurement
- Power computation by software
- High torsional stiffness
- Simple handling and assembly

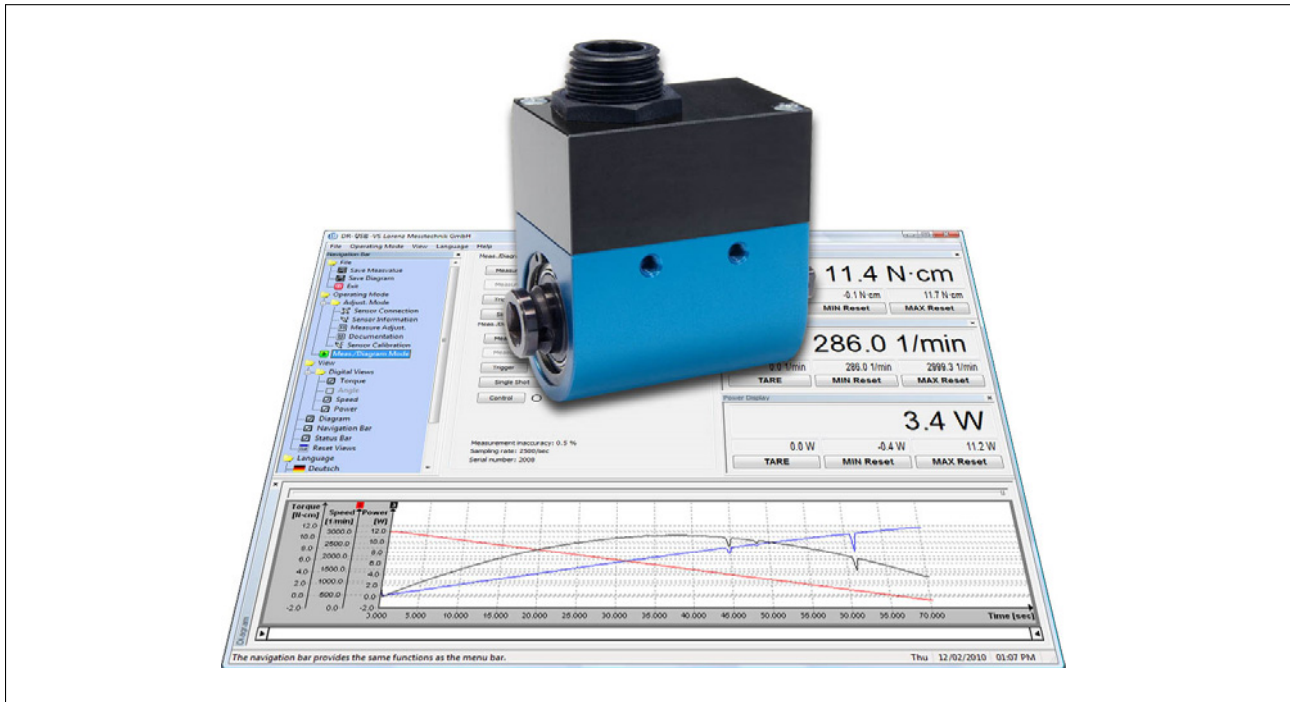

This sensor has a contactless and digital signal transmission from rotor to stator, which means no signal falsification and maintenance-free.

Specifications

Article-No.	Nominal Torque [N·m]	Limit Speed [min ⁻¹]	Springrate [N·m/rad]	Mass Moment of Inertia [kg·m ²]		Limit Thrust Load [N] ¹	Limit Shear Force [N] ²
				Drive Side	Test Side		
112859	0.1	3000	1.8E+01	2.1E-06	3.3E-07	42	1.2
112861	0.2	3000	1.8E+01	2.1E-06	3.3E-07	42	1.2
112862	0.5	3000	1.2E+02	2.1E-06	3.3E-07	185	2.9
112863	1	4000	1.2E+02	2.1E-06	3.3E-07	260	4.7
112916	2	4000	3.0E+02	2.1E-06	3.3E-07	480	12.2
112917	5	4000	5.9E+02	2.1E-06	3.5E-07	870	30
112918	10	4000	7.3E+02	2.1E-06	3.6E-07	1150	45
112919	15	4000	7.3E+02	2.1E-06	3.6E-07	1150	45
112920	20	4000	7.3E+02	2.1E-06	3.6E-07	1150	45
112921	35	3000	8.6E+03	1.0E-05	1.1E-05	3300	110
112922	50	3000	1.0E+04	1.0E-05	1.1E-05	4200	155
112923	63	3000	1.1E+04	1.0E-05	1.1E-05	4900	190
112924	100	2500	1.2E+04	1.6E-05	1.1E-05	4000	135
112925	160	2500	1.5E+04	1.6E-05	1.2E-05	5500	215
112926	200	2500	1.5E+04	1.6E-05	1.2E-05	5500	215
112928	500	2500	8.8E+04	9.9E-05	7.7E-05	13500	840
112929	1000	1500	1.3E+05	2.1E-04	1.1E-04	16500	1000
112930	2000	1000	2.1E+05	3.5E-03	1.8E-03	27000	1650
112932	5000	1000	2.6E+05	3.5E-03	1.8E-03	51000	4000

DR-3001		
Accuracy class torque	% f. s.	0.1
Speed resolution	min ⁻¹	1
Speed accuracy	% f. s.	±1
Angle of rotation resolution	degree	0.25
Repeatability (DIN 1319)	%	±0.02
Feed-in from USB	VDC	4 ... 6
Current consumption	mA	≤250
Output signal torque	digits	±25,000
Output signal speed/ angle of rotation	digits	±32,511
Control signal excitation		per Software
Sample rate	kSample/s	2.5
Reference temperature	°C	23
Nominal temperature range	°C	5 ... 45
Service temperature range	°C	0 ... 60
Storage temperature range	°C	-10 ... 70
Temperature coefficient of sensitivity	% f. s./K	±0.01
Temperature coefficient of zero signal	% f. s./K	±0.02
Service torque (static)	% f. s.	150
Limit torque (static)	% f. s.	200
Ultimate torque (static)	% f. s.	>300
Bandwidth (DIN 50 100)	%	70 (peak - peak)
Level of protection (DIN EN 60529)		IP50
Electrical connection		PX0446 IP68 B Mini USB, incl. 3 m connection cable to PC

¹ Unsupported shaft

² Unsupported shaft

Option Calibrations

Article-No.	Description	Steps	Norm
400676	Linearity diagram	25%	Factory standard
400664	Linearity diagram	10%	
400961	Proprietary calibration	3	VDI/VDE 2646
400700	Proprietary calibration	5	
400688	Proprietary calibration	8	
	DAkkS- Calibration		on request

Dimensions

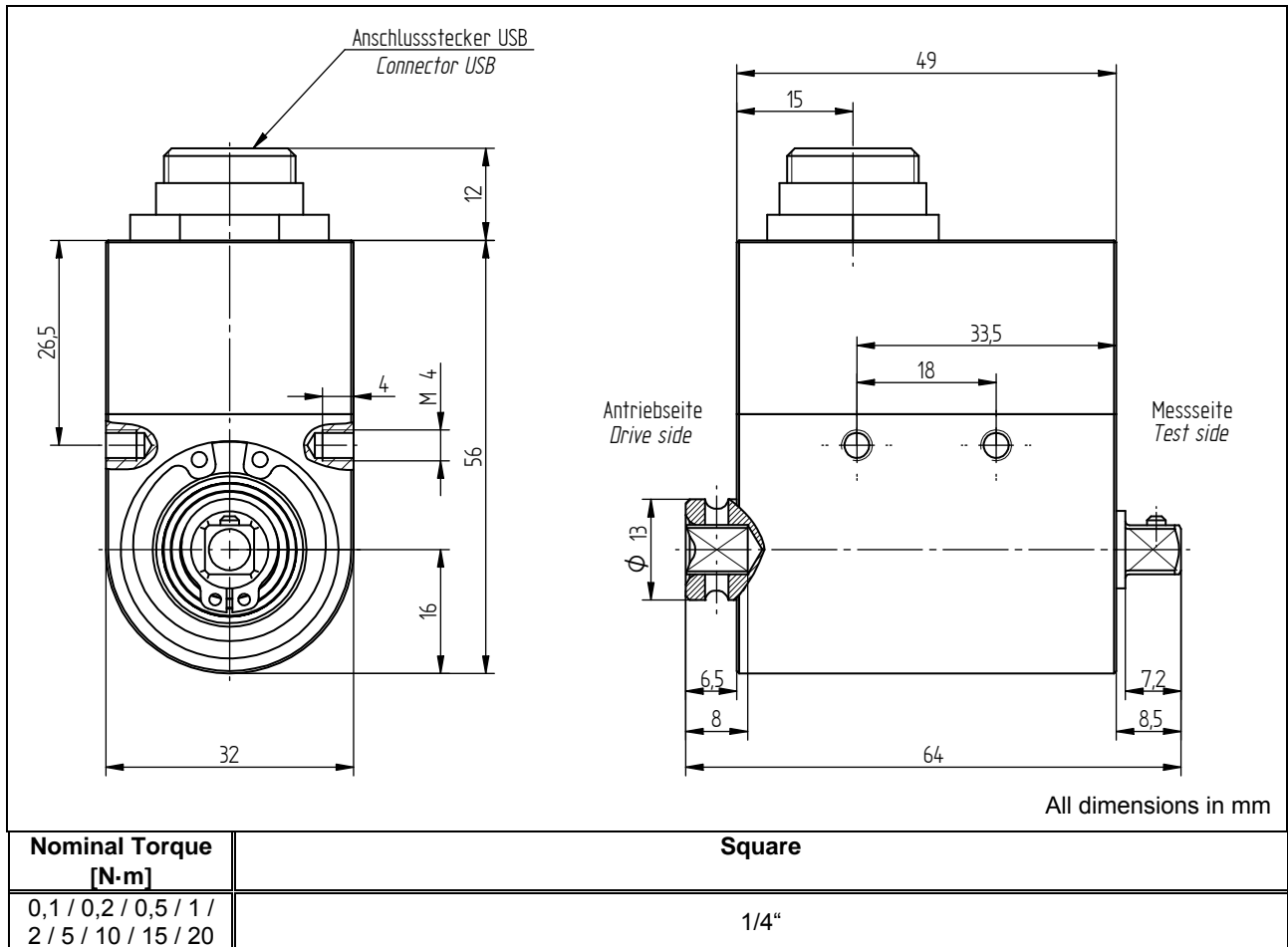

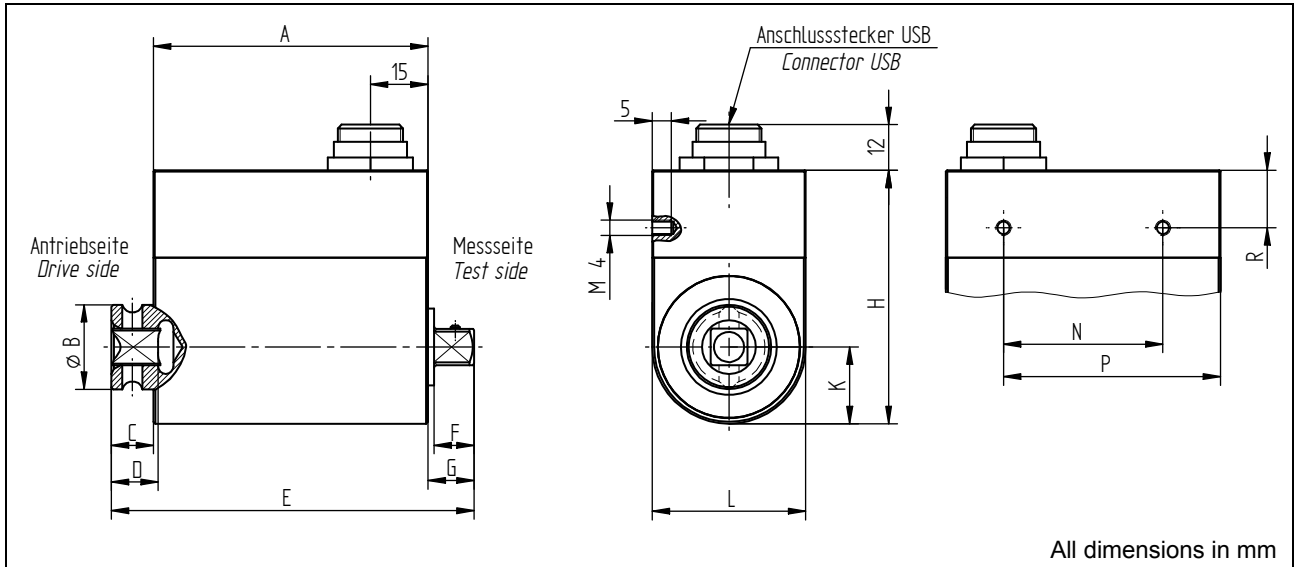

Nominal Torque [N·m]	Square	Dimensions [mm]												
		A	B	C	D	E	F	G	H	K	L	N	P	R
35 / 50 / 63	3/8"	71.5	22	11	12.2	94.5	10.4	12	66	20	40	41.5	56,5	15
100 / 160 / 200	1/2"	71.5	29.8	13	15	100.5	15.1	16	66	20	40	41.5	56,5	15

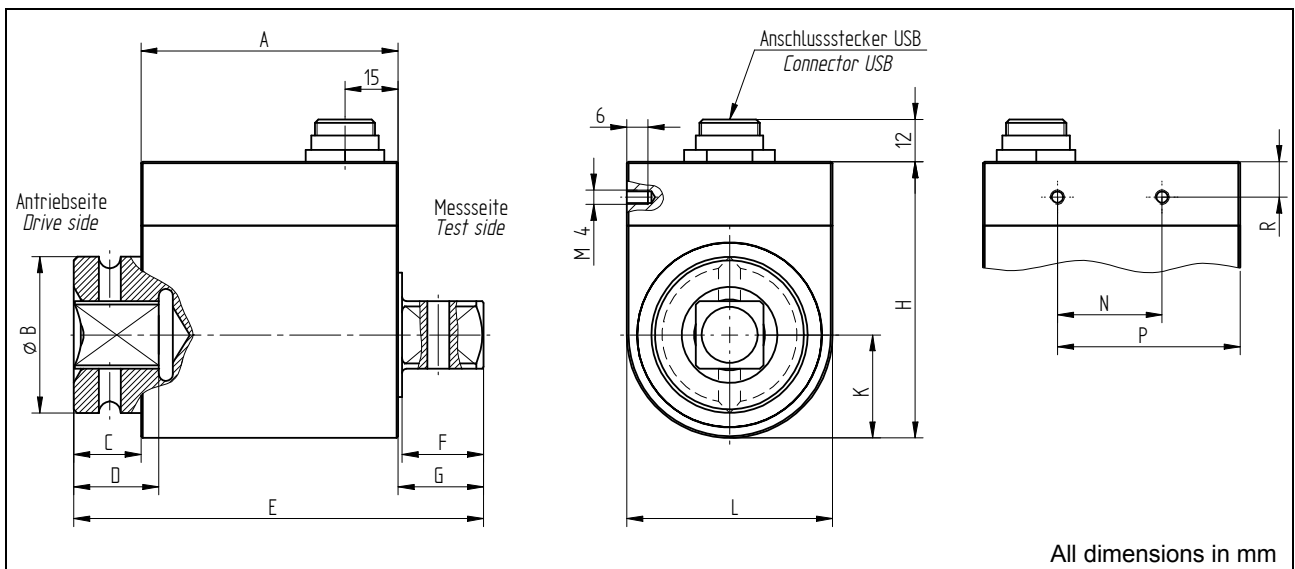

Nominal Torque [N·m]	Square	Dimensions [mm]												
		A	B	C	D	E	F	G	H	K	L	N	P	R
500	3/4"	72.5	44	19	24	115.5	22.9	24	77.8	29	58	29.5	51.5	10
1000	1"	72.5	54	29	29	130.5	27.4	29	77.8	29	58	29.5	51.5	10

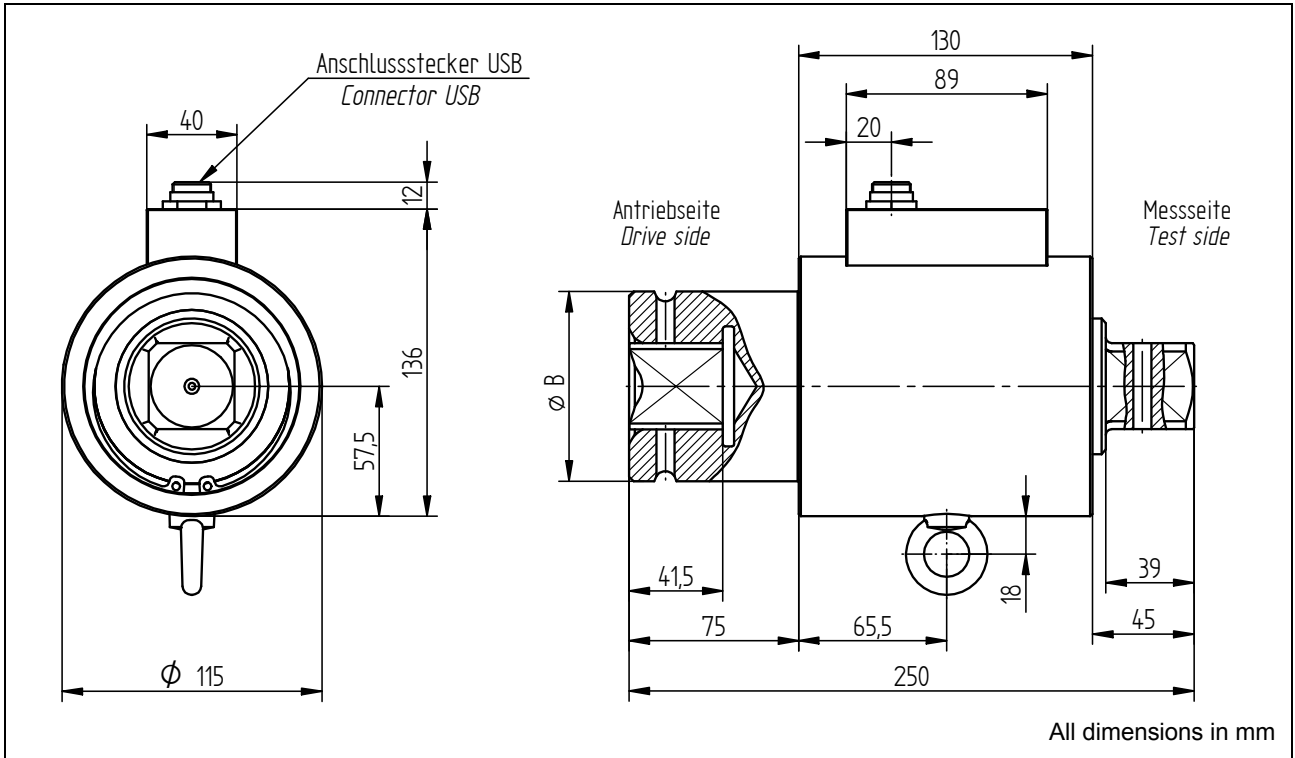

Nominal Torque [N·m]	Square
2000 / 5000	1 1/2"

Configuration and Evaluation Software

DR-USB-VS

- Convenient configuration and evaluation software
- Graphic presentation of torque/ speed/ power or torque/ angle of rotation
- Automatic scaling of y-axis
- Simultaneous storage of up to 3 physical values
- Automatic storage function of the measured values as CSV- or BMP-File

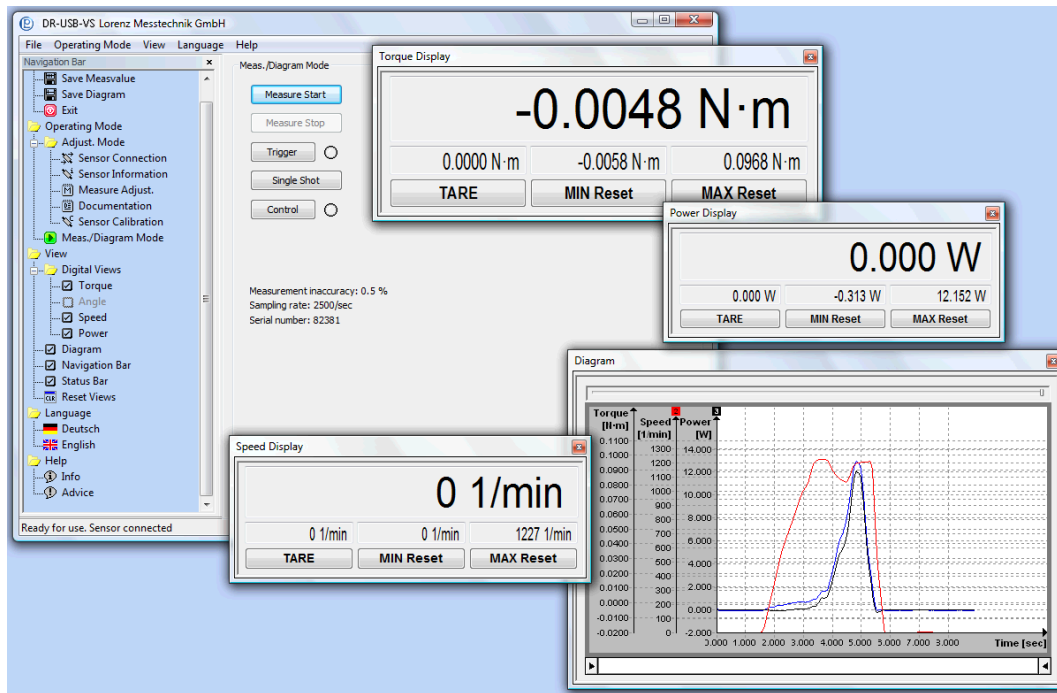

Description

Configuration and evaluation software for easy analysis and graphic presentation on a PC.

The software allows direct read in of measured data into a text file in CSV-Format through the USB-Port of a PC. This enables further analyses with a commercially available spreadsheet program at any time.

Specifications

Type	DR-USB-VS
Interface	USB
Protocol	Lorenz standard protocol
System Requirements	Windows® '03/ '08/ Vista/ 7/ 8 32/64 Bit ³ Dual-Core ex 1.8 GHz (with diagram)

Conversion in physical values	✓
Simultaneous measuring	1 Sensor
Graphic presentation of a physical value	✓
Automatic or manual storage in a CSV and BMP file	✓
Mathematical computation of the mechanical power	✓
Calibration function	✓
Resettable minimum value memory for each measured value	✓
Resettable maximum value memory for each measured value	✓
Variable average determination	✓
Tare for each measured value	✓

³ Windows® is either a registered brand or brand of the Microsoft Corporation in the USA and/or other countries.

All trademarks or brands used in this document refer only to the respective product or the holder of the trademark or brand. Lorenz Messtechnik GmbH does not raise claims to other than their own trademarks or brands.