

Krafteinleitungen - Gelenkösen mit Innen- oder Außengewinde

Force Transmissions - Joint eyes with female or male thread

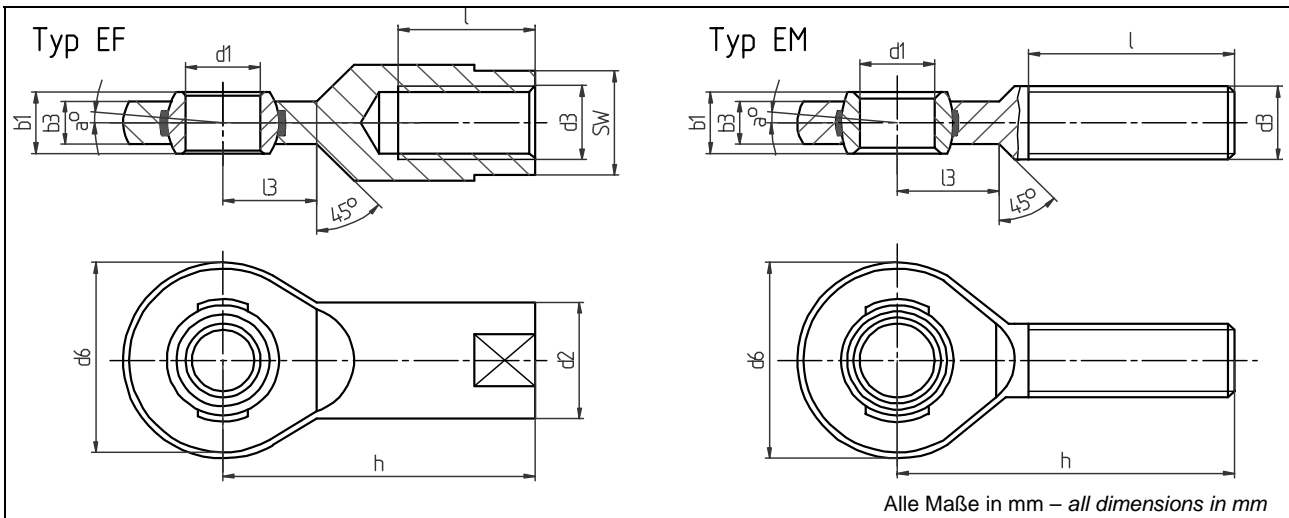

Art.-Nr. Art.-no.	Typ - Type EF	b 1	b 3	d 1	d 2	d 3	d 6	h	l	l 3	α	SW	Gewicht - Weight [kg]	Tragzahl - Load rating stat. C ₀ [N]
43805	EF 5	8	6	5	11	M5	18	27	10	10	7,5°	9	0,018	10800
42767	EF 6	6	4	6	10	M6	20	30	12	11	6,5°	9	0,017	10600
42768	EF 8	8	5	8	13	M8	23	36	16	12	8,0°	11	0,031	13100
42769	EF 10	9	6	10	16	M10	28	43	20	13	6,0°	14	0,054	18800
40585	EF 12	10	7	12	19	M12	32	50	22	15	5°	17	0,086	28000
40590	EF 17	14	10	17	25	M16	44	67	28	20	5,5°	22	0,208	57900
41433	EF 20	16	12	20	28	M20 x 1,5	51	77	33	23	4,5°	24	0,290	76700
40250	EF 25	20	16	25	35	M24 x 2	62	94	42	30	3,5°	30	0,57	119100
40588	EF 35	25	20	35	48	M36 x 3	82	125	61	38	3,5°	41	1,23	180800
40591	EF 45	32	25	45	65	M45 x 3	102	165	76	50	4°	55	3,085	276200
40218	EF 60	44	36	60	82	M60 x 4	135	225	103	70	3,5°	70	7,300	532100

Art.-Nr. Art.-no.	Typ - Type EM	b 1	b 3	d 1	d 3	d 6	h	l	l 3	α	Gewicht - Weight [kg]	Tragzahl - Load rating stat. C ₀ [N]
42764	EM 6	6	4	6	M6	20	36	22	11	6,5°	0,014	6400
42765	EM 8	8	5	8	M8	23	42	25	12	8°	0,024	11000
42766	EM 10	9	6	10	M10	28	48	29	15	6°	0,041	16800
40183	EM 12	10	7	12	M12	32	54	33	15	5°	0,067	23000
40589	EM 17	14	10	17	M16	44	69	40	23	5,5°	0,163	54100
41762	EM 20	16	12	20	M20 x 1,5	51	78	47	25	4,35°	0,270	76700
40294	EM 25	20	16	25	M24 x 2	62	94	57	32	3,5°	0,508	119100
40587	EM 35	25	20	35	M36 x 3	82	140	92	38	3,5°	1,330	180800
40592	EM 45	32	25	45	M45 x 3	102	165	100	50	4°	2,620	276200
40595	EM 60	44	36	60	M60 x 4	135	225	140	70	3,5°	6,400	532100

Toleranzen für Typen EF und EM - Tolerances for types EF and EM

d 1		Δd1		Δb1		Δh	
>	≤	Abmaße - Tolerance		Abmaße - Tolerance		Abmaße - Tolerance	
	5	+0,012	0	0	-0,12	+1,2	-1,2
5	18	0	-0,008	0	-0,12	+1,2	-1,2
18	30	0	-0,010	0	-0,12	+1,7	-1,7
30	50	0	-0,012	0	-0,12	+2,1	-2,1
50	80	0	-0,015	0	-0,15	+2,7	-2,7

Druckstück ED7 (für K-18) - Thrust piece ED7 (for K-18)

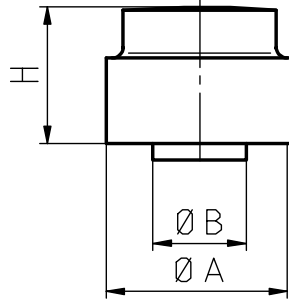

Alle Maße in mm – all dimensions in mm

Art.-Nr. Art.-no.	Messbereich - Measuring range [kN]	ØA	ØB	H
42953	5	12	5	20
42954	10	16	8	25
42955	20	24	15	30
42956	50	30	15	30
42957	100	37	20	40
42958	200	50	25	45
42959	500	62	30	50
42952	1000 / 2000	120	68	80
43913	3000	125	68	80
44161	5000	220	100	120

Bei der Bestellung bitte den gewünschten Messbereich angeben! Please specify requested nominal torque at order!

Druckstück und Befestigungsflansch EF42 (für K-450)

Thrust piece and mounting flange EF42 (for K-450)

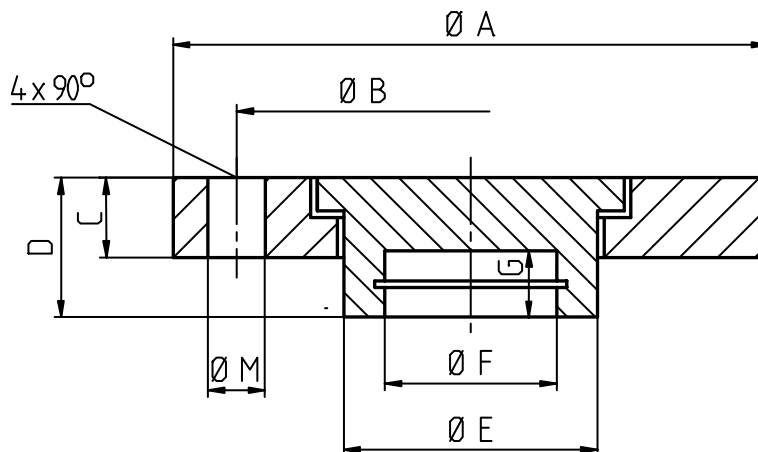

Alle Maße in mm – all dimensions in mm

Art.-Nr. Art.-no.	Messbereich - Measuring range [kN]	A	B	C	D	E	F	G	M
42770	1 / 2 / 5 / 10	89	70	12	21	37,9	13,6	6	8,5
42771	20 / 50	89	70	12	21	37,9	25,7	10	8,5
40755	100 / 200	115	90	14	28	47,9	33	10	12,5
42772	500 / 1000	149	120	18	50	81,9	46	12	16,5

Bei der Bestellung bitte den gewünschten Messbereich angeben! Please specify requested nominal torque at order!

Druckstück E2 (für K-11) - Thrust piece E2 (for K-11)

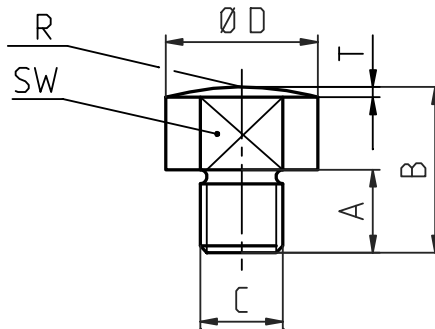

Alle Maße in mm – all dimensions in mm

Art.-Nr. Art.-no.	Messbereich - Measuring range [kN]	Ø D	A	B	C	SW	R	T
40324	0,5 / 1 / 2 / 5 / 10	22	12	24	M12	18	60	1
40325	20 / 50	52	15	30	M24 x 2	45	230	1,5
43914	100 / 200	65	15	30	M36 x 3	45	295	1,8
43732	500	85	20	40	M45 x 3	50	450	2,0
44087	1000	125	50	90	M80 x 4	95	780	2,5
48231	2000	190	70	120	M120 x 4	170	1000	4,5

Bei der Bestellung bitte den gewünschten Messbereich angeben! Please specify requested nominal torque at order!

Adapter E3 (für K-11) - Adapter E3 (for K-11)

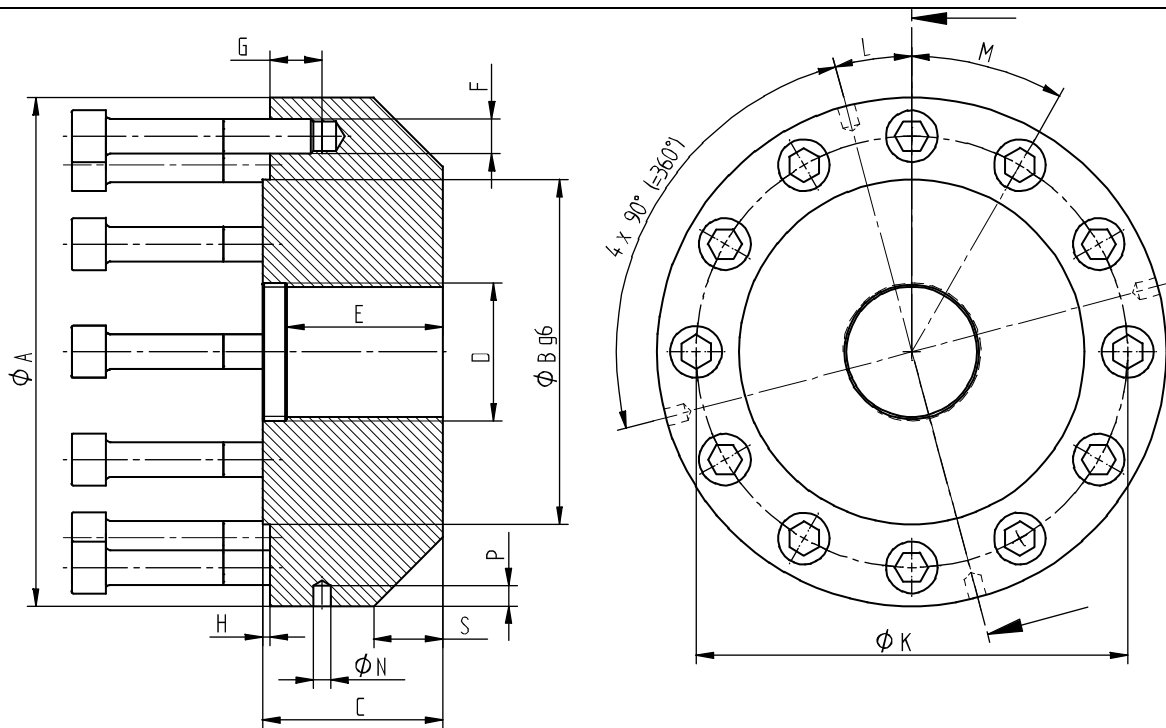

Alle Maße in mm – all dimensions in mm

Art.-Nr. Art.-no.	Messbereich - Measuring range [kN]	Ø A	Ø B	C	D	E	F	G	H	Ø K	L	M	Ø N	P	S
47625	0,5 / 1 / 2 / 5 / 10	90	60	36	M12	26	M6	13	2	75	22,5°	4x90°	4	6	15x45°
47626	20 / 50	150	105	42,5	M24 x 2	34,5	M10	15	2,5	130	22,5°	8x45°	6	8	20x45°
47627	100 / 200	185	135	46,5	M36 x 3	36	M12	19	2,5	160	22,5°	8x45°	6	8	20x45°
47628	500	240	160	64,5	M45 x 3	52,5	M16	27	2,5	200	15°	12x30°	8	10	28x45°
47629	1000	295	200	104,5	M80 x 4	90,5	M20	30	4,5	250	15°	12x30°	10	12	40x45°
47630	2000	390	270	140	M120 x 4	120	M24	38	3	330	7,5°	24x15°	12	14	60x45°

Bei der Bestellung bitte den gewünschten Messbereich angeben! Please specify requested nominal torque at order!