



SM7000 SERIES

MICROWAVE SWITCH

USER'S MANUAL

P/N: 82-0046-000
Release February 7, 2006

VXI Technology, Inc.
2031 Main Street
Irvine, CA 92614-6509
(949) 955-1894



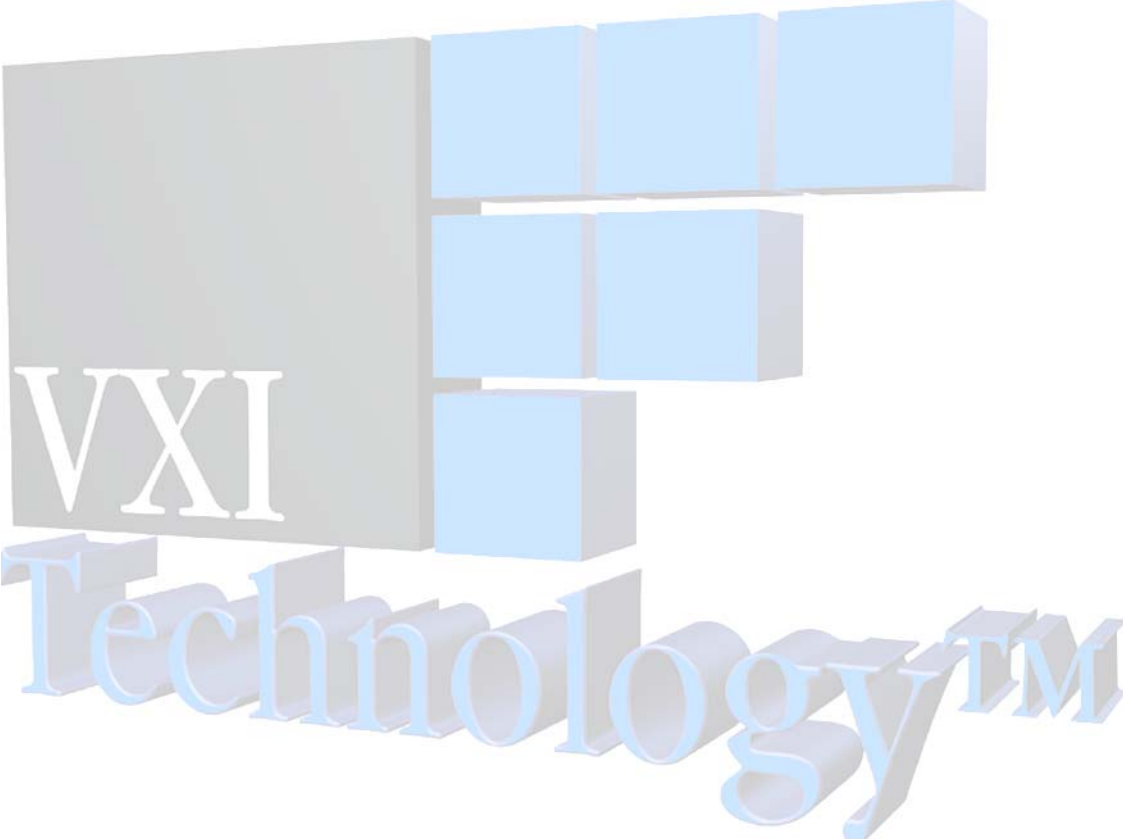

TABLE OF CONTENTS

INTRODUCTION

Certification.....	6
Warranty.....	6
Limitation of Warranty.....	6
Restricted Rights Legend	6
DECLARATION OF CONFORMITY	7
GENERAL SAFETY INSTRUCTIONS	8
Terms and Symbols.....	8
Warnings	8
SUPPORT RESOURCES.....	11
SECTION 1	13
INTRODUCTION	13
Overview.....	13
SM7000 Series Switch Options.....	14
Programming.....	15
Automatic Scanning.....	15
Programmable Timing Delays	15
Safety Interrupt	15
Break-Before-Make / Make-Before-Break Operation	15
SM7000 Series Specifications.....	16
SECTION 2	19
PREPARATION FOR USE	19
Introduction.....	19
Calculating System Power and Cooling Requirements.....	19
Setting the Chassis Backplane Jumpers	20
Setting the Logical Address	20
Selecting the Extended Memory Space.....	21
SECTION 3	23
PROGRAMMING	23
Register Access	23
Addressing	23
Description of Registers - A16.....	25
Description of SMIP II Module Registers - A24 / A32 - Extended Memory	34
DEVICE MEMORY MAP	38
Module Relay Control Address.....	38
Relay Register Offset	38
Writing to the Relays.....	38
Programming.....	39
SECTION 4	41
SWITCH CONFIGURATION.....	41
Introduction	41
SM7000 CONFIGURATION.....	42
Front Panel Connection - SM7000.....	42
SM7000 Connector Pin Assignments	43
SM7000 Relay Identification Table	44
SM7270 - Dual SPDT	45
SM7271 - SP3T.....	46
SM7272 - SP4T.....	47
SM7273 - SP5T.....	48
SM7274 - SP6T.....	49
SM7275 - Transfer Switch.....	50

SM7000 Microwave Switch Relay Register Map	51
SM7000 Switch / Relay Chart.....	51
SM7001A CONFIGURATION.....	52
Front Panel Connection - SM7001A	52
SM7001A Connector Pin Assignments - Interface to SMIP II Platform	53
Switch Option (SM73XX) to SM7001A Connection	53
SM7001A Relay Identification Table	54
SM7374 - SP6T.....	54
SM7001A Microwave Switch Relay Register Map	55
SM7001L CONFIGURATION	56
Front Panel Connection - SM7001L	56
Switch Module Installation	57
Switch Module Operation	57
SM7001L Connector Pin Assignments - Interface to SMIP II Platform.....	58
Switch Option (SM7374L) to SM7001L Connection	58
SM7374L - SP6T	59
SM7002 CONFIGURATION.....	61
Front Panel Connection - SM7002.....	61
SM7002 Microwave Switch Relay Register Map.....	62
SM7012L CONFIGURATION	63
Front Panel Connection - SM7012L	63
Switch Module Operation	64
SPDT Switch Schematic	65
SM7012L Microwave Switch Relay Register Map.....	66
SM7013L CONFIGURATION	67
Front Panel Connection - SM7013L	67
Switch Module Installation	68
Switch Module Operation	68
Switch Option (SM7374L) to SM7013L Connection	69
SPDT Switch Schematic	70
SM7374L - SP6T	71
SM7016L CONFIGURATION	73
Front Panel Connection - SM7016L	73
Switch Module Installation	74
Switch Module Operation	74
Switch Option (SM7374L) to SM7016L Connection	75
SPDT Switch Schematic	76
SM7374L - SP6T	77
32-CHANNEL RELAY DRIVER	79
Pin Assignments - J1	80
50-Pin Connector Detail.....	80
32-channel Relay Driver Schematic.....	81
Relay Driver Register Map	81
Interface Examples.....	82
PASS-THROUGH ADAPTERS.....	84
Introduction	84
Table 4-25 SM7000/7001A Pass-Through Adapter Connector Pin Assignments	85
Pass-Through Adapters - Connection Examples.....	86
INDEX	88

CERTIFICATION

VXI Technology, Inc. (VTI) certifies that this product met its published specifications at the time of shipment from the factory. VTI further certifies that its calibration measurements are traceable to the United States National Institute of Standards and Technology (formerly National Bureau of Standards), to the extent allowed by that organization's calibration facility, and to the calibration facilities of other International Standards Organization members.

WARRANTY

The product module (SM7000/7001A/7001L/7012L) referred to herein is warranted against defects in material and workmanship for a period of three years from the receipt date of the product at customer's facility. The same warranty applies to the product options (SM72XX/73XX/73XXL) and the SM7002 for a period of one year. The sole and exclusive remedy for breach of any warranty concerning these goods shall be repair or replacement of defective parts, or a refund of the purchase price, to be determined at the option of VTI.

For warranty service or repair, this product must be returned to a VXI Technology authorized service center. The product shall be shipped prepaid to VTI and VTI shall prepay all returns of the product to the buyer. However, the buyer shall pay all shipping charges, duties, and taxes for products returned to VTI from another country.

VTI warrants that its software and firmware designated by VTI for use with a product will execute its programming when properly installed on that product. VTI does not however warrant that the operation of the product, or software, or firmware will be uninterrupted or error free.

LIMITATION OF WARRANTY

The warranty shall not apply to defects resulting from improper or inadequate maintenance by the buyer, buyer-supplied products or interfacing, unauthorized modification or misuse, operation outside the environmental specifications for the product, or improper site preparation or maintenance.

VXI Technology, Inc. shall not be liable for injury to property other than the goods themselves. Other than the limited warranty stated above, VXI Technology, Inc. makes no other warranties, express or implied, with respect to the quality of product beyond the description of the goods on the face of the contract. VTI specifically disclaims the implied warranties of merchantability and fitness for a particular purpose.

RESTRICTED RIGHTS LEGEND

Use, duplication, or disclosure by the Government is subject to restrictions as set forth in subdivision (b)(3)(ii) of the Rights in Technical Data and Computer Software clause in DFARS 252.227-7013.

VXI Technology, Inc.
2021 Main Street
Irvine, CA 92614-6509 U.S.A.

DECLARATION OF CONFORMITY

Declaration of Conformity According to ISO/IEC Guide 22 and EN 45014

MANUFACTURER'S NAME	VXI Technology, Inc.
MANUFACTURER'S ADDRESS	2031 Main Street Irvine, California 92614-6509
PRODUCT NAME	Microwave Switch Module
MODEL NUMBER(S)	SM7000, SM7001A, SM7001L, SM7002, SM7012L, SM7013L, SM7016L
PRODUCT OPTIONS	All
PRODUCT CONFIGURATIONS	All

VXI Technology, Inc. declares that the aforementioned product conforms to the requirements of the Low Voltage Directive 73/23/EEC and the EMC Directive 89/366/EEC (inclusive 93/68/EEC) and carries the "CE" mark accordingly. The product has been designed and manufactured according to the following specifications:

SAFETY	EN61010 (2001)
EMC	EN61326 (1997 w/A1:98) Class A CISPR 22 (1997) Class A VCCI (April 2000) Class A ICES-003 Class A (ANSI C63.4 1992) AS/NZS 3548 (w/A1 & A2:97) Class A FCC Part 15 Subpart B Class A EN 61010-1:2001

The product was installed into a C-size VXI mainframe chassis and tested in a typical configuration.

I hereby declare that the aforementioned product has been designed to be in compliance with the relevant sections of the specifications listed above as well as complying with all essential requirements of the Low Voltage Directive.

February 2006



Steve Mauga, QA Manager

GENERAL SAFETY INSTRUCTIONS

Review the following safety precautions to avoid bodily injury and/or damage to the product. These precautions must be observed during all phases of operation or service of this product. Failure to comply with these precautions, or with specific warnings elsewhere in this manual, violates safety standards of design, manufacture, and intended use of the product.

Service should only be performed by qualified personnel.

TERMS AND SYMBOLS

These terms may appear in this manual:

WARNING Indicates that a procedure or condition may cause bodily injury or death.

CAUTION Indicates that a procedure or condition could possibly cause damage to equipment or loss of data.

These symbols may appear on the product:



ATTENTION - Important safety instructions



Frame or chassis ground



Indicates that the product was manufactured after August 13, 2005. This mark is placed in accordance with *EN 50419, Marking of electrical and electronic equipment in accordance with Article 11(2) of Directive 2002/96/EC (WEEE)*. End-of-life product can be returned to VTI by obtaining an RMA number. Fees for take-back and recycling will apply if not prohibited by national law.

WARNINGS

Follow these precautions to avoid injury or damage to the product:

Use Proper Power Cord To avoid hazard, only use the power cord specified for this product.

Use Proper Power Source To avoid electrical overload, electric shock, or fire hazard, do not use a power source that applies other than the specified voltage.

Use Proper Fuse To avoid fire hazard, only use the type and rating fuse specified for this product.

WARNINGS (CONT)

Avoid Electric Shock

To avoid electric shock or fire hazard, do not operate this product with the covers removed. Do not connect or disconnect any cable, probes, test leads, etc. while they are connected to a voltage source. Remove all power and unplug unit before performing any service. *Service should only be performed by qualified personnel.*

Ground the Product

This product is grounded through the grounding conductor of the power cord. To avoid electric shock, the grounding conductor must be connected to earth ground.

Operating Conditions

To avoid injury, electric shock or fire hazard:

- Do not operate in wet or damp conditions.
- Do not operate in an explosive atmosphere.
- Operate or store only in specified temperature range.
- Provide proper clearance for product ventilation to prevent overheating.
- **DO NOT** operate if you suspect there is any damage to this product. *Product should be inspected or serviced only by qualified personnel.*



Improper Use

The operator of this instrument is advised that if the equipment is used in a manner not specified in this manual, the protection provided by the equipment may be impaired. Conformity is checked by inspection.

SUPPORT RESOURCES

Support resources for this product are available on the Internet and at VXI Technology customer support centers.

VXI Technology World Headquarters

VXI Technology, Inc.
2031 Main Street
Irvine, CA 92614-6509

Phone: (949) 955-1894
Fax: (949) 955-3041

VXI Technology Cleveland Instrument Division

5425 Warner Road
Suite 13
Valley View, OH 44125

Phone: (216) 447-8950
Fax: (216) 447-8951

VXI Technology Lake Stevens Instrument Division

VXI Technology, Inc.
1924 - 203 Bickford
Snohomish, WA 98290

Phone: (425) 212-2285
Fax: (425) 212-2289

Technical Support

Phone: (949) 955-1894
Fax: (949) 955-3041
E-mail: support@vxitech.com



Visit <http://www.vxitech.com> for worldwide support sites and service plan information.

SECTION 1

INTRODUCTION

OVERVIEW

The SM7000 Series microwave switching modules are members of the VXI Technology SMIP *II*[™] family. They offer a modular design allowing custom switching configurations to be easily assembled and modified in the field.

The SM7000 is a single-wide, C-size VXI module, which can support up to six different microwave switches including: a dual SPDT; SP3T through SP6T; transfer switches and pass-through adapters that allow the module to control up to eight externally mounted relays each.

The SM7001A, SM7001L, SM7002-X, and the SM7012L are double-wide, C-size VXI modules, which can support up to four different microwave switches including: a terminated SP6T and pass-through adapters that allow the module to control up to eight externally mounted relays each. The SM7001L, SM7012L, SM7013L, and SM7016L differ from the other two double-wide modules in that their switches utilize latching relays.



FIGURE 1-1 SM7000 (LEFT) AND SM7002 (RIGHT) MICROWAVE SWITCH MODULES

Using the SMIP II family for microwave switching, the user obtains the following benefits over other VXI microwave switch solutions:

- Density:** Up to six (1 x 6) microwave relays can be housed in a single VXIbus slot (SM7000).
- Modularity:** Each SM7000 switch module can house up to six switches, or “building blocks”, which can be mixed and matched for the final configuration. There are up to seven of these “building blocks” from which to chose.

The following table lists the different switch available in the SM7000 series.

SM7000 SERIES SWITCH OPTIONS

SM7000 SERIES SWITCH OPTIONS	
SM7000 (DC - 18 GHz)	Relay Type
SM7270	Dual SPDT Fail Safe
SM7271	SP3T Non-latching
SM7272	SP4T Non-latching
SM7273	SP5T Non-latching
SM7274	SP6T Non-latching
SM7275	Transfer Switch Fail Safe
SM7276	Pass-Through Adapter
SM7001A (DC - 18 GHz)	Relay Type
SM7374	SP6T Non-latching
SM7376	Pass-Through Adapter
SM7000L (DC - 18 GHz)	Relay Type
SM7374L	SP6T Latching
SM7002 (DC - 40 GHz)	Relay Type
SM7002-1	SP3T Non-latching
SM7002-2	SP4T Non-latching
SM7002-3	SP5T Non-latching
SM7002-4	SP6T Non-latching
SM7012L (DC - 18 GHz)	Relay Type
Fixed SPDT Relays	SPDT Latching
SM7013L (DC - 18 GHz)	Relay Type
3 Fixed SPDT Relays	SPDT Latching
2 SM7374L	SP6T Latching
SM7016L (DC - 18 GHz)	Relay Type
6 Fixed SPDT Relays	SPDT Latching
2 SM7374L	SP6T Latching

PROGRAMMING

The SMIP II family of switch modules is programmed using direct register access for fast data throughput.

Automatic Scanning

A predefined sequence of channels can be programmed into an extensive scan list that can be incremented by a trigger. This approach relieves the host controller from having to tie up the VXibus backplane when scanning.

Programmable Timing Delays

A delay can be programmed between relay closures to allow for settling times of other system resources. When used with triggers, a controlled synchronous switching system can easily be configured.

Safety Interrupt

This is a programmable fail-safe feature that allows all relays to open based upon the occurrence of a selected TTL backplane trigger. This allows signals to be removed from the unit under test if a system fail-safe occurs, such as inadvertent removal of a test adapter.

Break-Before-Make / Make-Before-Break Operation

This feature allows automatic Break-Before-Make (BBM) and Make-Before-Break (MBB) operations. It is programmed simply by setting user configurable options. In BBM operation, all opening relays are guaranteed to open prior to any closing relays being set. The relay open or close time is user configurable as well. In MBB operation, the closing relays are guaranteed to be set prior to the opening relays being opened.

SM7000 SERIES SPECIFICATIONS

SM7000 SPECIFICATIONS**MAXIMUM POWER HANDLING (CW)**

At 18 GHz 20 W

SWITCHING TIME

< 15 ms

RF IMPEDANCE50 Ω **FREQUENCY (GHz)**

dc – 3

3 – 8

8 – 12.4

12.4 – 20

Isolation (dB min)

80

70

60

60

Insertion Loss (dB max)

0.2

0.3

0.4

0.5

VSWR

1.2:1

1.3:1

1.4:1

1.5:1

SM7001A SPECIFICATIONS**MAXIMUM POWER HANDLING (CW)**

At 18 GHz 3 W

SWITCHING TIME

< 15 ms

RF IMPEDANCE50 Ω **FREQUENCY (GHz)**

dc – 3

3 – 8

8 – 12.4

12.4 – 18

Isolation (dB min)

80

70

60

60

Insertion Loss (dB max)

0.2

0.3

0.4

0.5

VSWR

1.2:1

1.3:1

1.4:1

1.5:1

SM7001L SPECIFICATIONS**MAXIMUM POWER HANDLING (CW)**

At 3 GHz < 100 W @ 3 GHz

At 20 GHz < 40 W @ 20 GHz

Into Termination < 1 W

SWITCHING TIME

< 15 ms

RF IMPEDANCE50 Ω **FREQUENCY (GHz)**

dc – 3

3 – 8

8 – 12.4

12.4 – 20

Isolation (dB min)

80

70

60

60

Insertion Loss (dB max)

0.2

0.3

0.4

0.5

VSWR

1.2:1

1.3:1

1.4:1

1.5:1

SM7002 SPECIFICATIONS**MAXIMUM POWER HANDLING (CW)**

At 40 GHz 3 W

SWITCHING TIME

< 15 ms

RF IMPEDANCE50 Ω **FREQUENCY (GHz)**

dc – 6

6 – 12

12 – 18

18 -26.5

26.5 -40

Isolation (dB min)

70

60

60

55

50

Insertion Loss (dB max)

0.2

0.4

0.5

0.7

0.9

VSWR

1.3:1

1.4:1

1.5:1

1.7:1

2.0:1

SM7012L SPECIFICATIONS**MAXIMUM POWER HANDLING (CW)**

At 3 GHz	< 100 W @ 3 GHz
At 20 GHz	< 40 W @ 20 GHz
Into Termination	< 1 W

SWITCHING TIME

< 15 ms

RF IMPEDANCE50 Ω **FREQUENCY (GHz)**

	dc – 3	3 – 8	8 – 12.4	12.4 – 20
Isolation (dB min)	80	70	60	60
Insertion Loss (dB max)	0.2	0.3	0.4	0.5
VSWR	1.2:1	1.3:1	1.4:1	1.5:1

SM7013L SPECIFICATIONS**MAXIMUM POWER HANDLING (CW)**

At 3 GHz	< 100 W @ 3 GHz
At 20 GHz	< 40 W @ 20 GHz
Into Termination	< 1 W

SWITCHING TIME

< 15 ms

RF IMPEDANCE50 Ω **FREQUENCY (GHz)**

	dc – 3	3 – 8	8 – 12.4	12.4 – 20
Isolation (dB min)	80	70	60	60
Insertion Loss (dB max)	0.2	0.3	0.4	0.5
VSWR	1.2:1	1.3:1	1.4:1	1.5:1

SM7016L SPECIFICATIONS**MAXIMUM POWER HANDLING (CW)**

At 3 GHz	< 100 W @ 3 GHz
At 20 GHz	< 40 W @ 20 GHz
Into Termination	< 1 W

SWITCHING TIME

< 15 ms

RF IMPEDANCE50 Ω **FREQUENCY (GHz)**

	dc – 3	3 – 8	8 – 12.4	12.4 – 20
Isolation (dB min)	80	70	60	60
Insertion Loss (dB max)	0.2	0.3	0.4	0.5
VSWR	1.2:1	1.3:1	1.4:1	1.5:1

SECTION 2

PREPARATION FOR USE

INTRODUCTION

When the SMIP *II* is unpacked from its shipping carton, the contents should include the following items:

- (1) SM7000 Series Microwave Switch module
- (1) SM7000 Series Microwave Switch User's Manual (this manual)

All components should be immediately inspected for damage upon receipt of the unit.

Once the SMIP *II* is assessed to be in good condition, it may be installed into an appropriate C-size or D-size VXibus chassis in any slot other than slot zero. The chassis should be checked to ensure that it is capable of providing adequate power and cooling for the SMIP *II*. Once the chassis is found adequate, the SMIP *II*'s logical address and the chassis' backplane jumpers should be configured prior to the SMIP *II*'s installation.

CALCULATING SYSTEM POWER AND COOLING REQUIREMENTS

It is imperative that the chassis provide adequate power and cooling for this module. Referring to the chassis operation manual, confirm that the power budget for the system (the chassis and all modules installed therein) is not exceeded and that the cooling system can provide adequate airflow at the specified backpressure.



It should be noted that if the chassis cannot provide adequate power to the module, the instrument may not perform to specification or possibly not operate at all. In addition, if adequate cooling is not provided, the reliability of the instrument will be jeopardized and permanent damage may occur. Damage found to have occurred due to inadequate cooling would also void the warranty of the module.

SETTING THE CHASSIS BACKPLANE JUMPERS

Please refer to the chassis operation manual for further details on setting the backplane jumpers.

SETTING THE LOGICAL ADDRESS

The logical address of the SMIP II is set by two rotary switches located on the top edge of the interface card, near the backplane connectors. Each switch is labeled with positions 0 through F. The switch closer to the front panel of the module is the least significant bit (**LSB** or “**Front**”), and the switch located towards the back of the module is the most significant bit (**MSB** or “**Back**”). To set the Logical Address (LA), simply rotate the pointer to the desired value. For example, to set the **LA** to **25**, first convert the decimal number to the hexadecimal value of **19**. Next, set the back switch to **1**, and the front switch to **9**. See Figure 2-1. Two examples are provided below:

Example 1

LA (decimal)	Divide by 16	MSB	LSB	
25	25 / 16 =	1	w/ 9 remaining	<i>Divide the decimal value by 16 to get the MSB and the LSB.</i>
		= 0001	1001	<i>The 1 is the MSB, and the remainder of 9 is the LSB.</i>
		= 1	9	<i>Convert to hexadecimal. Set the back switch to 1 and the front switch to 9.</i>

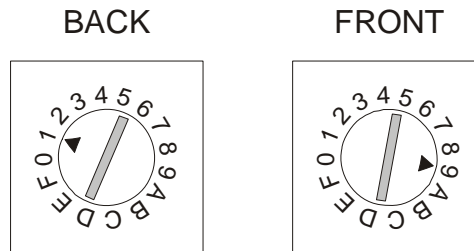
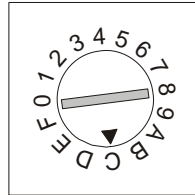
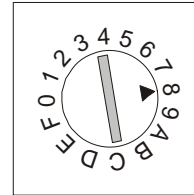

FIGURE 2-1 LOGICAL ADDRESS EXAMPLE 1

Example 2

LA (decimal)	Divide by 16	MSB	LSB	
200	200 / 16 =	12	w/ 8 remaining	<i>Divide by 16.</i>
	=	1100	1000	<i>Convert to MSB and LSB.</i>
	=	C	8	<i>Convert to hexadecimal. Set the back switch to C and the front switch to 8.</i>

BACK**FRONT****FIGURE 2-2 LOGICAL ADDRESS EXAMPLE 2**

Here is another way of looking at the conversion:

$$\begin{aligned} \text{LA} &= (\text{back switch} \times 16) + \text{front switch} \\ \text{LA} &= (1 \times 16) + 9 \\ \text{LA} &= 16 + 9 \\ \text{LA} &= 25 \end{aligned}$$

Set the address switches to **FF** for dynamic configuration. Upon power-up, the resource manager will assign a logical address. See Section F - Dynamic Configuration in the *VXibus Specification* for further information.

There is only one logical address per SMIP II base unit. Address assignments for individual modules are handled through the A24/A32 address space allocation.

SELECTING THE EXTENDED MEMORY SPACE

The Extended Memory Space of the SMIP II base units are set by a DIP-switch that is located on the bottom edge of the interface card. Position 1, located to the left on the DIP-switch, selects between A24 and A32 memory address space. In the UP position, the SMIP II will request A24 space. In the DOWN position (factory default), the SMIP II will request A32 space. (Position 2 is not currently used.) The selection of the address space should be based upon the memory allocation requirements of the system that the SMIP II module will be installed. The amount of memory allocated to an SMIP II module is independent of the address space selected.

SECTION 3

PROGRAMMING

REGISTER ACCESS

The SM7000 series modules are VXIbus register-based devices for high-speed data retrieval. Register-based programming is a series of **reads** and **writes** directly to the switch module registers. This eliminates the time for command parsing thus increasing speed.

ADDRESSING

The VTI switching modules utilize either the A24 or A32 space of the shared-memory architecture. To read or write to a module register, a register address needs to be specified. This is done by using the offset value (assigned by the resource manager) and multiplying it by 256 or 64 kB to get the base address in A24 or A32 address space, respectively

$$\text{A24 Base Address} = \text{Offset value} * 0x00FF \text{ (or 256)}$$

$$\text{A32 Base Address} = \text{Offset value} * 0xFFFF \text{ (or 65,535)}$$

The A24 or A32 offset value, assigned by the resource manager, can also be accessed by reading the A16 Offset Register. To address the A16 Offset Register use the following formula:

$$\text{A16 Base Address} = (\text{Logical Address} * 64) + 0xC000 \text{ (or 49,152)}$$

then

$$\text{A16 Offset Register Address} = \text{A16 Base Address} + 6$$

See Table 4.1 for the A16 Memory Map and the A24/A32 address space allocation.

TABLE 4-1 SMIP II REGISTER MAP - A16

OFFSET	WRITE FUNCTION	READ FUNCTION
0x3E	Trace Advance	Board Busy
0x3C	Busy Trigger Control	Busy Trigger Control
0x3A	Trace RAM Control	Trace RAM Control
0x38	TTL Trigger Polarity	Reserved
0x36	Open Trigger Select	Reserved
0x34	Trace ADV Trigger Select	Reserved
0x32	Trace RAM Address LOW	Trace RAM Address LOW
0x30	Trace RAM Address HIGH	Trace RAM Address HIGH
0x2E	Trace RAM End LOW	Trace RAM End LOW
0x2C	Trace RAM End HIGH	Trace RAM End HIGH
0x2A	Trace RAM Start LOW	Trace RAM Start LOW
0x28	Trace RAM Start HIGH	Trace RAM Start HIGH
0x26	Module 5, 4 Used Address	Reserved
0x24	Module 3, 2 Used Address	Reserved
0x22	Module 1, 0 Used Address	Reserved
0x20	NVM Access Register	NVM Access Register
0x1E	Reserved	Subclass Register
0x1C	Interrupt Control	Interrupt Control
0x1A	Reserved	Interrupt Status
0x18	Reserved	Reserved
0x16	Reserved	Reserved
0x14	Reserved	Reserved
0x12	Reserved	Reserved
0x10	Reserved	Reserved
0x0E	Reserved	Version Number
0x0C	Reserved	Serial Number LOW
0x0A	Reserved	Serial Number HIGH
0x08	Reserved	Reserved
0x06	Offset Register	Offset Register
0x04	Control Register	Status Register
0x02	Reserved	Device Type Register
0x00	LA Register	ID Register

NOTE: As members of the SMIP II series, the *SM7000 Series* microwave modules allocate for six (6) module boards, but only implement Module 0. Modules 1 - 5 are unused.

DESCRIPTION OF REGISTERS - A16

The following describes the registers shown in the SMIP II Register Map for A16 address space.

ID Register (0x00) — Read Only		
D11-D0	Manufacturer's ID	VXI Technology, Inc., set to F4B ₁₆
D13-D12	Address Space	A16/A24 = 00 ₂ A16/A32 = 01 ₂
D15-D14	Device Class	Extended register based device, set to 01 ₂

Logical Address Register (0x00) — Write Only		
D7-D0	Logical Address	Sets the new logical address in a dynamically configured module. When set for dynamic configuration (set to FF ₁₆) a soft reset will not alter the configured logical address, while a hard reset will set the register back to FF ₁₆ .
D15-D8	Reserved	Writing to this range has no effect.

Device Type Register (0x02) — Read Only		
D11-D0	Model Code	Model 277, set to 115 ₁₆
D15-D12	Required Memory	2 MB, set to 2 ₁₆ , for A24 2 MB, set to A ₁₆ , for A32

Status Register (0x04) — Read Only		
D15	A24/A32 Active	1 = indicates that A24/A32 memory space access is enabled 0 = indicates that A24/A32 memory space access is locked out
D14	MODID*	1 = indicates that the module is not selected by the MODID line 0 = indicates that the module is selected by the MODID line.
D13-D4	Reserved	These bits always read as 11,1111,1111 ₂
D3	Ready	This bit always reads as 1 ₂
D2	Passed	This bit always reads as 1 ₂
D1-D0	Reserved	These bits always read as 11 ₂

Control Register (0x04) — Write Only		
D15	A24/A32 Enable	1 = write a 1 to this bit to enable A24/A32 memory access 0 = to disable access
D14-D2	Reserved	Writes to these bits have no effect.
D1	Sysfail Inhibit	Write a 1 to this bit to prevent the module from asserting the SYSFAIL* line.
D0	Reset	1 = write a 1 to this bit to force the module into a reset state 0 = write a 0 to release the reset state

Offset Register (0x06) — Read and Write		
D15-D0	A24/A32 Memory Offset	The value written to this 16-bit register, times 256, sets the base address of the A24 memory space used by the module. The value written to this 16-bit register, times 65,536, sets the base address of the A32 memory space used by the module. A read from this register reflects the previously written value. Because of the required memory size, bits D4 - D0 are disregarded on writes and always read back as 0. Upon receiving a hard reset, all bits in this register are set to 0. A soft reset does not affect the value in this register.

Reserved Register (0x0A) — Read Only		
D15-D0	Not Implemented	Always read back as FFFF ₁₆

Reserved Register (0x0C) — Read Only		
D15-D0	Not Implemented	Always read back as FFFF ₁₆

Version Number Register (0x0E) — Read Only		
D15-D8	Firmware Version Number	Not applicable, reads back as FF ₁₆
D7-D4	Major Hardware Version Number	Depends on the specific hardware revision of the SMIP II interface board.
D3-D0	Minor Hardware Version Number	Depends on the specific hardware revision of the SMIP II interface board.

Interrupt Status Register (0x1A) — Read Only		
D15	Scan Function done	The latest scan list update is complete.
D14	Openbus Active Event true	The Openbus was activated by one or more programmed inputs. See description of the Openbus in the module register section.
D13-D8	Modules 0 - 5 Busy complete	D13 = Module 5, D12 = Module 4, ... and D8 = Module 0. The programmed Busy signal from one of the modules has timed out. This indicates that the relays actuated for that Busy cycle have settled and a measurement may take place.
D7-D0	Reserved	Always reads back as FFFF ₁₆
<p>Note: This status register may be used in a polled fashion rather than allowing the events above to generate an Interrupt. A read of this register will clear any active bits. Bits that are not set, or are about to be set are not affected by a read of this register.</p>		

Interrupt Control Register (0x1C) — Read and Write		
D15	Scan Function done mask bit	0 = enabled 1 = disabled
D14	Openbus Active Event true mask bit	0 = enabled 1 = disabled
D13-D8	Module 0 - 5 Busy complete	0 = enabled 1 = disabled D13 = Module 5, D12 = Module 4, ... and D8 = Module 0.
D7	IR ENA*	0 = writing a 0 to this bit enables interrupter capabilities 1 = writing a 1 to this bit disables interrupter capabilities
D6	IH ENA*	The module has no interrupt handler capability; therefore writing a 1 or 0 has no effect. A 1 is always read back for this bit.
D5-D3	Interrupter IRQ Line	The complement of the value programmed into these three bits reflects the selected IRQ line used by the module. A value of 011 ₂ would select IRQ4, a value of 000 ₂ would select IRQ7, and a value of 111 ₂ would disconnect the IRQ lines.
D2-D0	Handler IRQ Line	The module has no interrupt handler capability; therefore writing to these bits has no effect. A 111 ₂ is always read back for these bits.
<p>Note that all bits in this register are set to 1 upon receipt of a hard or soft reset.</p>		

Subclass Register (0x1E) — Read Only		
D15	VXIbus Extended Device	Always reads as 1.
D14-D0	Extended Memory Device	Always reads as 7FFD ₁₆

NVM Access Resister (0x20) — Read Only		
D15-D1	Unused	All Bits are always 1.
D0		Reads back the serial data stream from the selected SMIP <i>II</i> board. Note that only one SMIP <i>II</i> board may be read back at a time.

NVM Access Resister (0x20) — Write Only		
D15-D7	Unused	Data written to these bits have no effect.
D6		Serial clock for module 5; should be a logic 1 when not used.
D5		Serial clock for module 4; should be a logic 1 when not used.
D4		Serial clock for module 3; should be a logic 1 when not used.
D3		Serial clock for module 2; should be a logic 1 when not used.
D2		Serial clock for module 1; should be a logic 1 when not used.
D1		Serial clock for module 0; should be a logic 1 when not used.
D0		Serial data input for all modules; must be a logic 1 when not used.

Board X, Y Used Address Register (0x22, 0x24, 0x26) — Read and Write		
D15-D8		Sets the actual number of words of address space used by the relays on board's X.
D7-D0		Sets the actual number of words of address space used by the relays on board's Y.

Trace RAM Start High Register (0x28) — Read and Write		
D15-D4	Unused	Data written to these bits have no effect and always read back as 1.
D3-D0		Sets the four most significant bits of the starting address of the Trace RAM, allowing the available RAM to be divided into multiple traces.

Trace RAM Start Low Register (0x2A) — Read and Write		
D15-D0		Sets the 16 least significant bits of the starting address of the Trace RAM, allowing the available RAM to be divided into multiple traces.

Trace RAM End High Register (0x2C) — Read and Write		
D15-D4	Unused	Data written to these bits have no effect and always read back as 1.
D3-D0		Sets the four most significant bits of the ending address of the Trace RAM, allowing the available RAM to be divided into multiple traces.

Trace RAM End Low Register (0x2E) — Read and Write		
D15-D0		Sets the 16 least significant bits of the ending address of the Trace RAM, allowing the available RAM to be divided into multiple traces.

Trace RAM Address HIGH Register (0x30) — Read and Write		
D15-D4	Unused	Data written to these bits have no effect and always read back as 1.
D3-D0		Sets and reads back the four most significant bits of the current address of the Trace RAM, allowing the current trace RAM address to be queried and changed.

Trace RAM Address LOW Register (0x32) — Read and Write		
D15-D0		Sets and reads back the sixteen least significant bits of the current address of the Trace RAM, allowing the current trace RAM address to be queried and changed.

Trace Advance Trigger Select Register (0x34) — Write Only		
D15-D8		Sets the TTLTRIG line or lines, which are configured as outputs, and will toggle when Trace Advance condition occurs in the module. D15 corresponds to TTLTRIG7, D14 to TTLTRIG6, ... and D8 to TTLTRIG0. Setting a bit to a 1 enables the trigger line, setting a bit to 0 disables the corresponding line. All bits are set to 0 when either a soft or a hard reset is received by the module.
D7-D0		Sets the TTLTRIG line or lines, which are configured as inputs, and will cause a Trace Advance event to occur in the module. D7 corresponds to TTLTRIG7, D6 to TTLTRIG6, ... and D0 to TTLTRIG0. Setting a bit to a 1 enables the trigger line, setting a bit to 0 disables the corresponding line. All enabled TTLTRIG lines are OR'd together to allow more than one TTLTRIG line to cause a Trace Advance event to occur. All bits are set to 0 when the module receives either a soft or a hard reset.

Open Trigger Select Register (0x36) —Write Only		
D15-D8		Sets the TTLTRIG line or lines, which are configured as outputs, and will toggle when Relay Open condition occurs in the module. D15 corresponds to TTLTRIG7, D14 to TTLTRIG6, ... and D8 to TTLTRIG0. Setting a bit to a 1 enables the trigger line, setting a bit to 0 disables the corresponding line. All bits are set to 0 when either a soft or a hard reset is received by the module.
D7-D0		Sets the TTLTRIG line or lines, which are configured as inputs, and will cause a Relay Open event to occur in the module. D7 corresponds to TTLTRIG7, D6 to TTLTRIG6, ... and D0 to TTLTRIG0. Setting a bit to a 1 enables the trigger line, setting a bit to 0 disables the corresponding line. All enabled TTLTRIG lines are OR'd together to allow more than one TTLTRIG line to cause a Relay Open event to occur. All bits are set to 0 when the module receives either a soft or a hard reset.

TTL Trigger Polarity Register (0x38) —Write Only		
D15-D14	Unused	Data written to these bits have no effect.
D13-D8	FAIL LED Control	D13 is for module 5, D12 is for module 4, ... D8 is for module 0. 0 = Off, 1 = On.
D4	Board Busy Trigger Slope	0 acts on the falling edge, 1 acts on the rising edge.
D3	Relay Open Input Slope	0 acts on the falling edge, 1 acts on the rising edge.
D2	Relay Open Output Slope	0 sets the falling edge active, 1 sets the rising edge active.
D1	Trace Advance Input Slope	0 advances on the falling edge, 1 advances on the rising edge.
D0	Trace Advance Output Slope	0 sets the falling edge active, 1 sets the rising edge active.
Note: A hard or a soft reset sets D3 - D0 to 0.		

Trace RAM Control Register (0x3A) — Read and Write		
D15-D10	Modules Installed	D15 is for module 5, D10 is for module 0. Set to 0 if the module is installed or set to a 1 if not installed. These bits are set to 0 at power on. By setting a 1, the SMIP II Interface PCB will generate DTACK for any read or write cycles to the memory space of the uninstalled plug-in modules.
D9-D4	Modules used in trace mode	D9 is for module 5, D4 is for module 0. Set to 1 if the module is used in trace mode, set to 0 if not in trace mode.
D3-D2	Unused	Data written to these bits have no effect. The value written is read back.
D1	LOOP ENABLE	1 = Enabled, 0 = Disabled. If enabled, the trace resumes at the start of active RAM and continues from there. If disabled, the trace stops at the end of active RAM and clears the TRACE ENABLE bit.
D0	TRACE ENABLE	1 = enabled, 0 = disabled. If the LOOP ENABLE bit is set and the end of active trace RAM is reached, this bit will not be reset.

Busy Trigger Control Register (0x3C) — Read and Write		
D15-D8	TTLTRIG Select	Sets the TTLTRIG Line or Lines, which are configured as outputs, and will toggle at the de-assertion of a Board Busy condition sent by the plug-in modules. D15 corresponds to TTLTRIG7, D14 to TTLTRIG6, ... and D8 to TTLTRIG0. Setting a bit to a 1 enables the trigger line, setting a bit to a 0 disables the corresponding line. All bits are set to 0 when either a soft or a hard reset is received by the module.
D7-D6	Unused	Data written to these bits have no effect. The value written is read back.
D5-D0	Busy Trigger Enable	Enables the Board Busy signals received from the plug-in modules to generate a trigger condition on the TTL Trigger Bus. D5 corresponds to Board Busy Module 5, D4 to Board Busy Module 4, ... and D0 to Board Busy Module 0. Setting a bit to a 1 enables the generation of a Trigger condition; setting a bit to a 0 disables the corresponding line. All bits are set to 0 when either a soft or a hard reset is received by the module. Software can be written to enable the last board updated to generate the TTLTrigger condition, alerting any other instruments that the plug-in modules' relays have settled. Alternatively, all of the plug-in modules may be enabled to generate the TTLTrigger condition.

Trigger Advance Register (0x3E) — Write Only		
D15-D0	Unused	The act of writing to this location causes a Trace Advance event to occur in the module. The specific data written to these bits has no effect.

Board Busy Register (0x3E) — Read Only		
D15-D7	Unused	These bits always read back as 1.
D6		Indicates whether the SMIP II platform is a single or double-wide. 0 = single wide 1 = double-wide
D5		A 0 read from this bit indicates the relays on module 5 have settled, a 1 indicates that the relays on module 5 are still changing state.
D4		A 0 read from this bit indicates the relays on module 4 have settled, a 1 indicates that the relays on module 4 are still changing state.
D3		A 0 read from this bit indicates the relays on module 3 have settled, a 1 indicates that the relays on module 3 are still changing state.
D2		A 0 read from this bit indicates the relays on module 2 have settled, a 1 indicates that the relays on module 2 are still changing state.
D1		A 0 read from this bit indicates the relays on module 1 have settled, a 1 indicates that the relays on module 1 are still changing state.
D0		A 0 read from this bit indicates the relays on module 0 have settled, a 1 indicates that the relays on module 0 are still changing state.

Reserved Registers — Read and Write		
D15-D0	Unused	Writing to these registers has no effect and will always read back as FFFF ₁₆ .

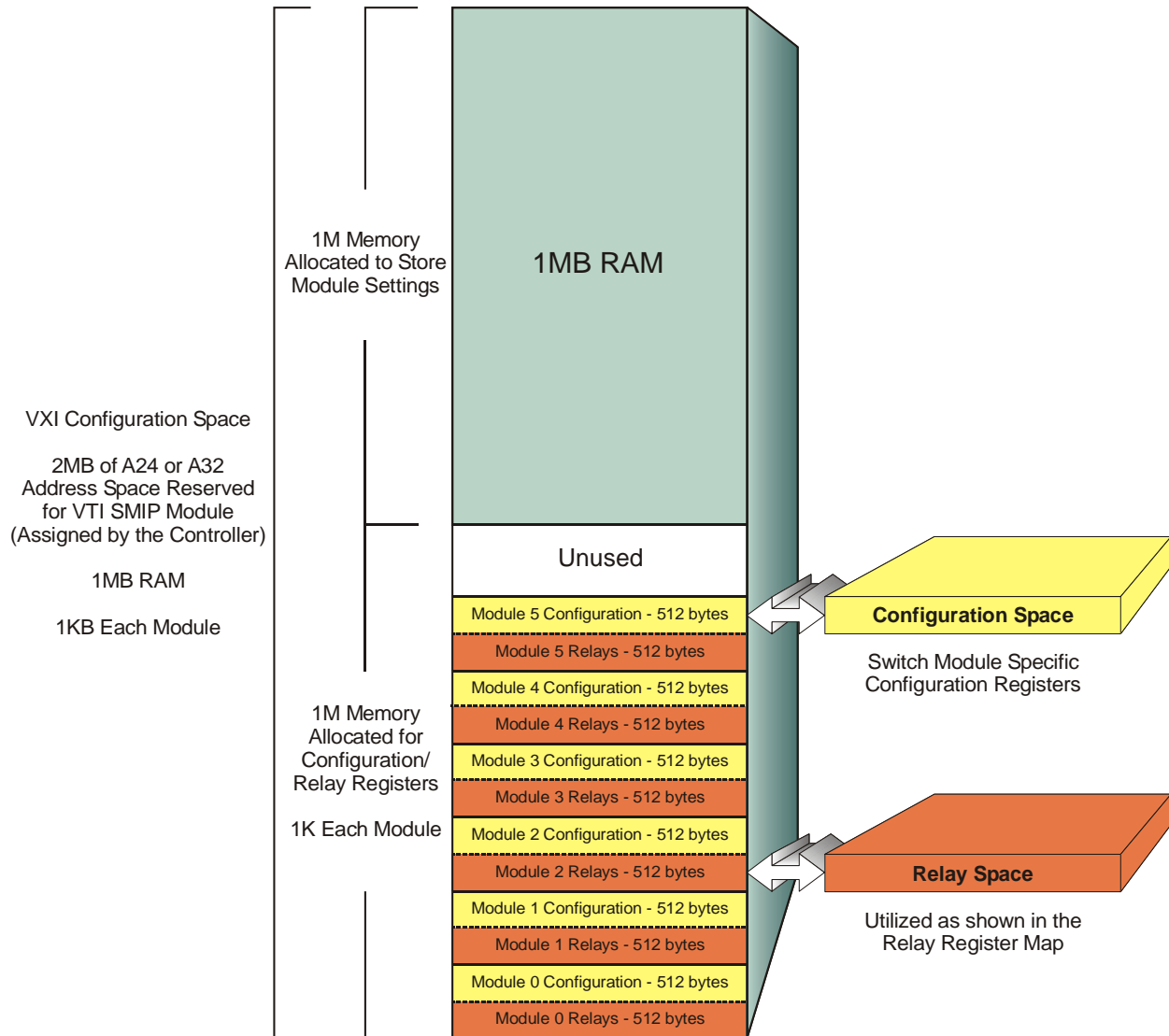

FIGURE 4-1 A24/A32 ADDRESS SPACE

Note: As members of the SMIP II series, the *SM7000 Series* microwave switch modules allocate for six (6) module boards, but only implement Module 0. Modules 1 - 5 are unused.

DESCRIPTION OF SMIP II MODULE REGISTERS - A24 / A32 - EXTENDED MEMORY

Each module is assigned 1 k (1024) bytes of memory as shown in the SMIP II Configuration/Relay Register Map for A24/A32 address space. The upper 512 bytes of memory space are used for module configuration registers. The following describes these registers.

Control Register — Read and Write		
ADDR	Plug-In LA+0x200	
D15-D11	Unused	
D10	Latch Operation Select	<p>0 = Operation is set to single coil reset 1 = Operation is set to multiple coil set/reset Pon state = 0</p> <p>This bit controls the rest operation of the latching relays used on this module. Relays that have a separate “set” and “reset” coil for each contact should use multiple coil set/reset operation.</p> <p>This bit is exclusive to modules containing latching relays (SM70XXL). This bit is unused in the SM7000, SM7001A and SM7002-X.</p>
D9	Relay Data Read Back Polarity Bit	<p>0 = Normal polarity relay data is read back from this module 1 = Inverted polarity relay data is read back from this module Pon state = 0</p> <p>This bit may be used to invert the relay data read back from the plug-in module. Control, Delay and Status Register read backs are not affected by this bit.</p>
D8	ACFAILN Enable Bit	<p>0 = ACFAILN is enabled to reset this module's relays 1 = ACFAILN is disabled from resetting this module's relays Pon state = 0</p>

Control Register — Read and Write (Continued)		
D7	BBM/MBB Enable Bit	<p>0 = BBM (Break-Before-Make) / MBB (Make-Before-Break) operation on this plug-in module is disabled 1 = BBM/MBB operation on this plug-in module is enabled Pon state = 0</p> <p>If this bit is set, the relays on this module will be sequenced to effect proper BBM or MBB operation. If this bit is not set, the plug-in module will process the newly written relay data as immediate data, writing it directly to the relay driver ports. No BBM or MBB sequencing will take place.</p> <p>While this feature is enabled, the initial write to the module will start the delay timer running and begin the BBM or MBB operation. Since the relays are controlled by the 16-bit registers, only the effected 16 relays will perform the BBM/MBB operation. To overcome this fact, any subsequent writes to the module, during the initial delay timer time-out period, will be accepted and processed. In addition, the delay time will be reset and begin counting down again. Once the delay timer has timed-out (this indicates that the relays have settled into their BBM/MBB state), writes to the module will not be accepted and may result in a Bus Error depending on the value programmed into the delay timer. This is because the delay timer is reset at the end of the initial time-out and is used to time the final relay closure into their post BBM/MBB state. The module Busy signal will only complete once the final relay closure state is reached.</p> <p>If this bit is set and no value has been loaded into the Delay Register, the plug-in module will act as if this enable bit is not set and load all of the relay drivers with immediate data.</p>
D6	BBM/MBB Select Bit	<p>0 = BBM operation on this plug-in module is selected 1 = MBB operation on this plug-in module is selected Pon state = 0</p>
D5	Access LED Fail Bit	<p>0 = non-active 1 = active Pon state = 0</p> <p>Lights the Access LED red when activated.</p>
D4	Relay Reset Enable Bit	<p>0 = The Openbus and Front Panel Open signals are not enabled to reset this module's relays 1 = The Openbus or Front Panel Open signal may be selected to reset this module's relays Pon state = 0</p>
D3	Relay Reset Select Bit	<p>0 = Front Panel Open signal is selected to reset this module's relays 1 = The Openbus signal is selected to reset this module's relays Pon state = 0</p> <p>Many plug-in modules may be programmed to be listeners on the Openbus.</p>

Control Register — Read and Write (Continued)		
D2	Openbus Out Enable Bit	<p>0 = Disables this module's Front Panel Open signal from driving the Openbus signal 1 = Enables this module's Front Panel Open signal to drive the Openbus Pon state = 0</p> <p>Many plug-in modules may be programmed to be talkers on the Openbus.</p>
D1	Front Panel Open Signal Polarity Bit	<p>0 = Non-inverted Front Panel Open signal polarity 1 = Inverted Front Panel Open signal polarity Pon state = 0</p> <p><i>Non-inverted:</i> If set in pulse mode, the Front Panel Open signal will generate a reset pulse on a falling edge. If set in level mode, the Front Panel Open signal will generate a reset signal on a low input signal.</p> <p><i>Inverted:</i> If set in pulse mode, the Front Panel Open signal will generate a reset pulse on a rising edge. If set in level mode, the Front Panel Open signal will generate a reset signal on a high input signal.</p>
D0	Front Panel Open Signal Operation Select Bit	<p>0 = Pulse mode 1 = Level mode Pon state = 0</p> <p><i>Pulse mode:</i> An edge seen at the Front Panel Open signal pin will generate a reset pulse that may be used to reset system relays. The pulse is of approximately 300 ns duration.</p> <p><i>Level mode:</i> A level present on the Front Panel Open signal pin will generate a reset signal that may be used to reset system relays. This signal will remain active as long as the input is active.</p> <p>On the front panel of most SMIP II plug-in modules, there are two pins for access to the module's Front Panel Open signal. These are the Front Panel Open signal pin and a ground reference pin. The purpose of the Front Panel Open signal is to allow user access to a configurable interlock feature that will reset all of the SMIP II system relays. The Front Panel Open signal may be used to reset the relays only on the module, which initiated the Front Panel Open signal fault condition. It also may be used to broadcast to all the other SMIP II plug-in modules installed in a SMIP II Interface Module via what is called the Openbus. Any plug-in module may be programmed to drive and/or listen to the Openbus. The Openbus signal may also be used to generate a wider chassis level fault signal via the TTL Trigger Bus (see the register definitions for A16 address space). The Front Panel Open signal is meant to be driven by either a switch closure or TTL/CMOS logic gate. It is pulled high on the module.</p>

Delay Register — Read and Write		
ADDR	Plug-In LA+0x202	
D15-D0	Data Bus 16-bit	<p>This register is used to set the time that the plug-in module will hold the Board Busy signal active. The Board Busy signal is set every time the plug-in receives a Write to a relevant Relay Register memory space. The Board Busy signal will be removed at the end of the time out that is set by the value contained in this register. For each count loaded into this register, the Board Busy signal will be held active for 1 μs. The delay may be set from 0 to approximately 65 ms, thus accommodating a wide variation in test station requirements.</p> <p>The Board Busy signal may be monitored by the user, in either a polled or an interrupt fashion, and is to be used as an indication that the relays in the newly actuated path have settled. Alternatively, the Board Busy signal may also be used to drive the TTL Trigger Bus. See the Board Busy, Interrupt Control and Busy Trigger Control Register descriptions in the A16 address space.</p>

Status Register — Read Only		
ADDR	Plug-In LA+0x204	
D15-D13	Hardware Revision Code	
D12-D1	Unused	
D0	Front Panel Open signal set by this module	<p>0 = Indicates that this module's Front Panel Open signal was not activated by the user 1 = An indication that this module's Front Panel Open signal was activated as programmed by the user Pon state = 0</p> <p>A read of this bit location will indicate whether the Front Panel Open signal was triggered from this plug-in module's front panel. In the event that multiple talkers have been programmed to drive the Openbus signal, this bit may be queried by the user to discover which module's Front Panel Open signal caused the Openbus Active Event to occur. A read of this register clears this bit to 0.</p>

DEVICE MEMORY MAP

MODULE RELAY CONTROL ADDRESS

Each module is assigned 1 kB (1024 bytes) of memory as shown in the SMIP *II* Configuration/Relay Register Map for A24/A32 address space. The lower 512 bytes of each module's memory is used for relay control. Each module is assigned its own base address. These base addresses are in 1 kB increments as follows:

Module 0 (J100) Base Address = H0000
 Module 1 (J101) Base Address = H0400
 Module 2 (J102) Base Address = H0800
 Module 3 (J103) Base Address = H0C00
 Module 4 (J104) Base Address = H1000
 Module 5 (J105) Base Address = H1400

Note: The SM7000 series microwave modules, being members of the SMIP *II* series, allocate for six (6) module boards, but only implement Module 0. Modules 1 - 5 are unused.

The Module Base Address is then added to the A24/A32 Base Address to access a specific module's relays:

$$\text{Module Relay Address} = \text{A24/A32 Base Address} + \text{Module Base Address}$$

RELAY REGISTER OFFSET

The Relay Register Offset is located within the module's A24/32 address space. When you send data to the register, the relay register offset is added to the A24/A32 base address and module base address:

$$\text{Relay Register Address} = \text{A24/A32 Base Address} + \text{Module Base Address} + \text{Register Offset}$$

or

$$\text{Relay Register Address} = \text{Module Relay Address} + \text{Register Offset}$$

WRITING TO THE RELAYS

Each bit of a 16-bit register represents the state of the relay (1 = closed, 0 = open). To change the state of any relay, it is only necessary to write a 16-bit integer to the specified register with the new configuration:

Relay Register Address, **data**

For example:

- writing a data value of "0" to the register at offset "0" would open the first sixteen relays
- writing a data value of 65535 to the same register would close the first 16 relays
- writing a data value of 65534 to the same register would close all relays except K1, which would be open

PROGRAMMING

With the introduction of VISA, sending a command to a register-based device is as simple as sending a command to a message-based device. Whether the application is graphical or standard, sending commands to the register-based device is just as intuitive. The VISA template for transferring data to a register-based device, utilizing A32 extended memory space, is as follows:

```
viOut16 (Handle, VI_A32_SPACE, Offset, Data)
```

Handle is passed by reference whenever a VISA session to a particular device is opened.

VI_A32_SPACE is defined in the VISA header file. (VI_A16_SPACE and VI_A24_SPACE are also valid.)

Offset is determined from the memory map and is in decimal format.

Data is a 16-bit signed integer value representing the state of the relays.

The following example is for a SMP5001, 80-channel SPST relay card utilizing A32 extended memory space. To close relays K1, K33 and K48 while leaving the other relays open, the following commands would be sent:

```
viOut16 (Handle, VI_A32_SPACE, 0, 1)      'closes relay 1
viOut16 (Handle, VI_A32_SPACE, 4, 32769)  'closes relay 33 and 48
```

VISA is the software architecture standard instituted by the VXI*plug&play* Alliance and is at a very high level of communication to a VXIbus device. The same philosophy and simplicity applies if the instrument is being programmed via lower level commands of an API (Application Programmer's Interface).

The individual device Relay Register Maps can be found in Section 4.

SECTION 4

SWITCH CONFIGURATION

INTRODUCTION

This section show configuration and connector information for the SM7000 Series Microwave Switches. The information on the following pages are divided into sub-sections as follows: SM7000, SM7001A, SM7001L, SM7002, SM7012L, SM7013L, SM7016L, 32-channel Relay Driver and Pass-Through Adapters.

SM7000 CONFIGURATION

FRONT PANEL CONNECTION - SM7000

As part of the SMIP II family of instruments, the SM7000 can hold a combination of switch options. The following pages list the switch options available for the SM7000 and the connector information.

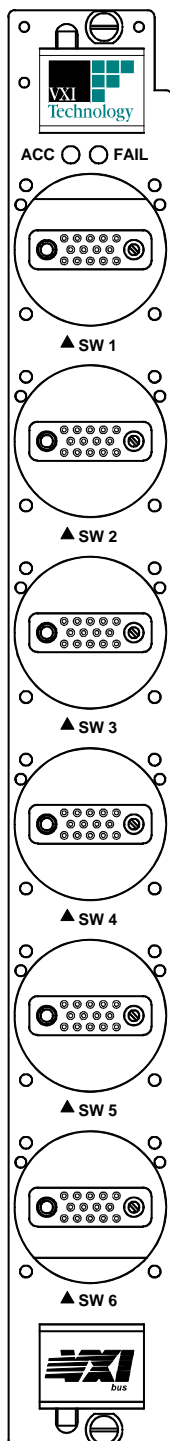

FIGURE 4-1 SM7000 FRONT PANEL (W/O SWITCHES INSTALLED)

TABLE 4-1 SM7000 CONNECTOR PIN ASSIGNMENTS

Pin Number	Description
A	Relay Common (+24 V)
B	K1
C	K2
D	K3
E	K4
F	K5
H	K6
J	K7
K	K8
L	Ground
M	ID0
N	ID1
P	ID2
R	ID3

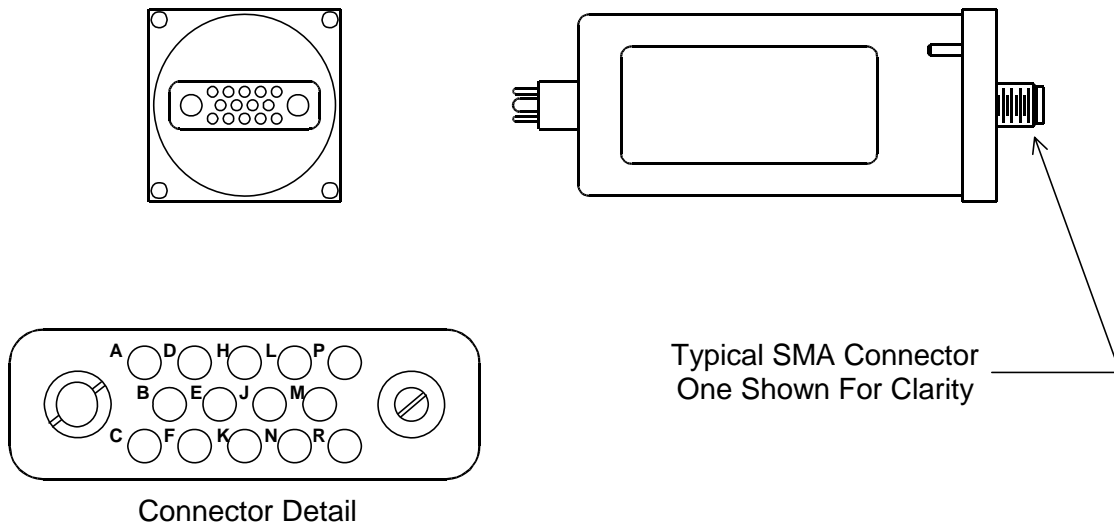

FIGURE 4-2 SWITCH OPTION (SM72XX) TO SM7000 CONNECTION

TABLE 4-2 SM7000 RELAY IDENTIFICATION TABLE

Model DC - 18GHz	Relay Type	ID3	ID2	ID1	ID0	VTI Part No.
SM7270	Dual SPDT Fail Safe	OPEN	OPEN	COM	OPEN	56-0020-002
SM7271	SP3T Non-Latching	OPEN	OPEN	COM	COM	56-0020-003
SM7272	SP4T Non-Latching	OPEN	COM	OPEN	OPEN	56-0020-004
SM7273	SP5T Non-Latching	OPEN	COM	OPEN	COM	56-0020-005
SM7274	SP6T Non-Latching	OPEN	COM	COM	OPEN	56-0020-006
SM7275	Transfer Switch Fail Safe	OPEN	COM	COM	COM	56-0020-007

The following pages show the schematics and connector layouts for the above switch options.

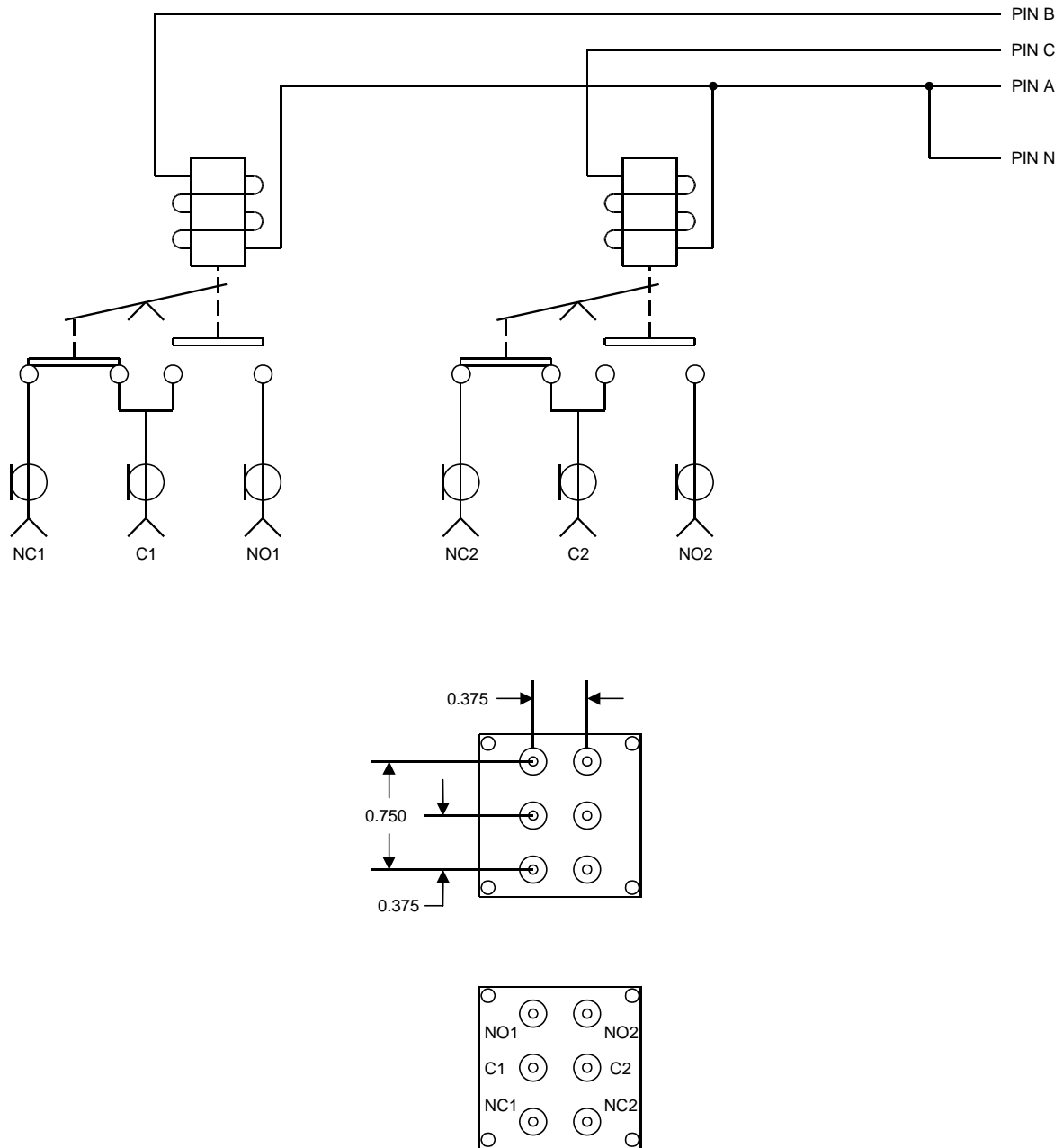

FIGURE 4-3 SM7270 - DUAL SPDT

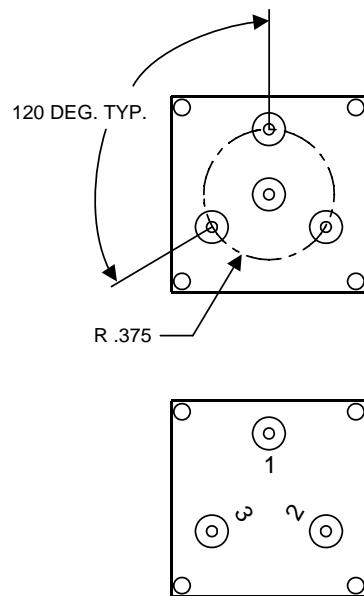
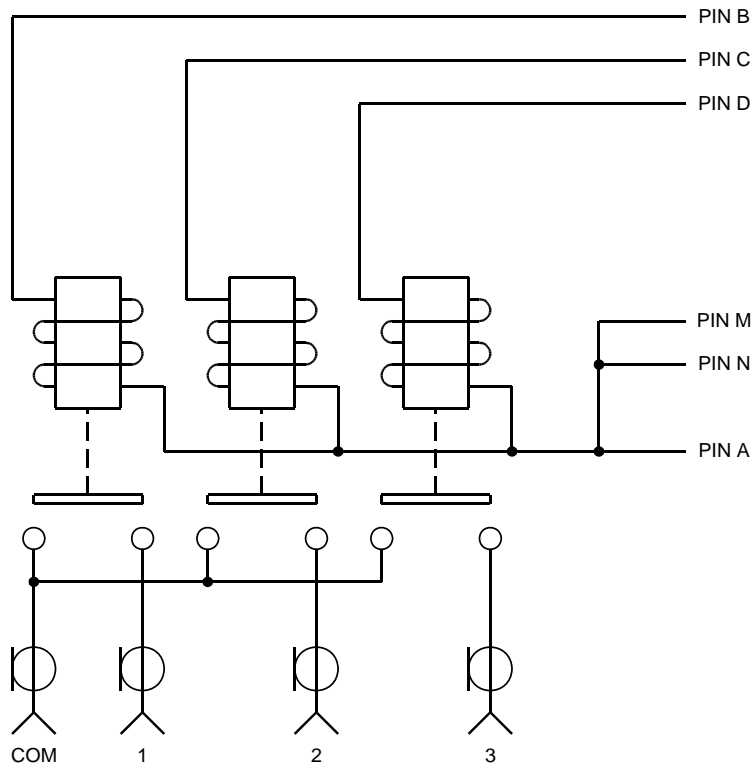

FIGURE 4-4 SM7271 - SP3T

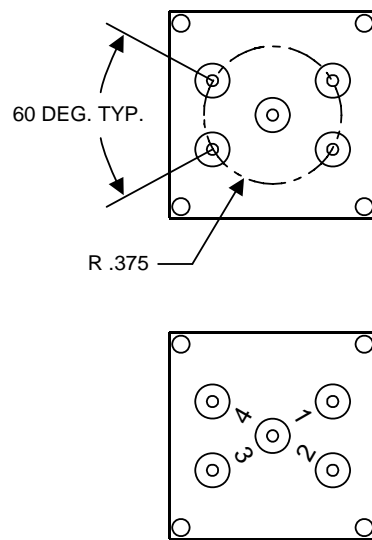
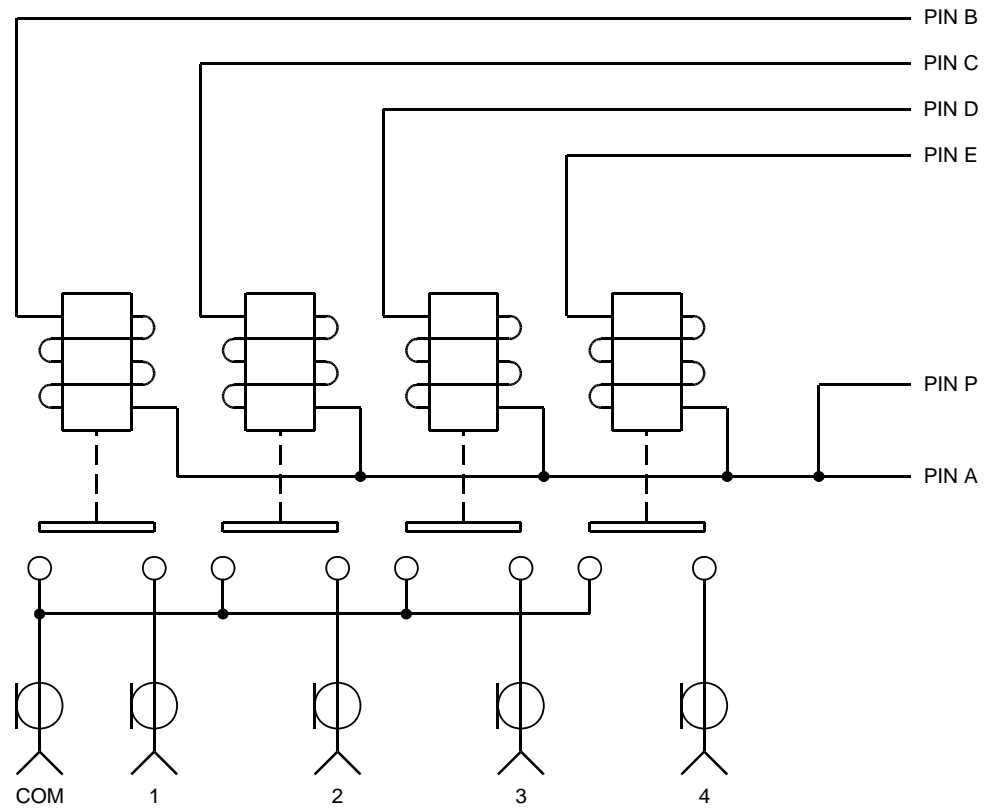

FIGURE 4-5 SM7272 - SP4T

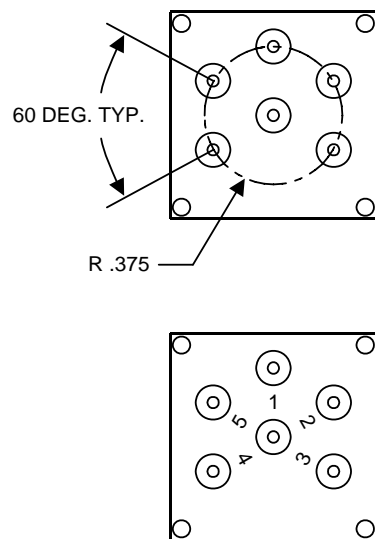
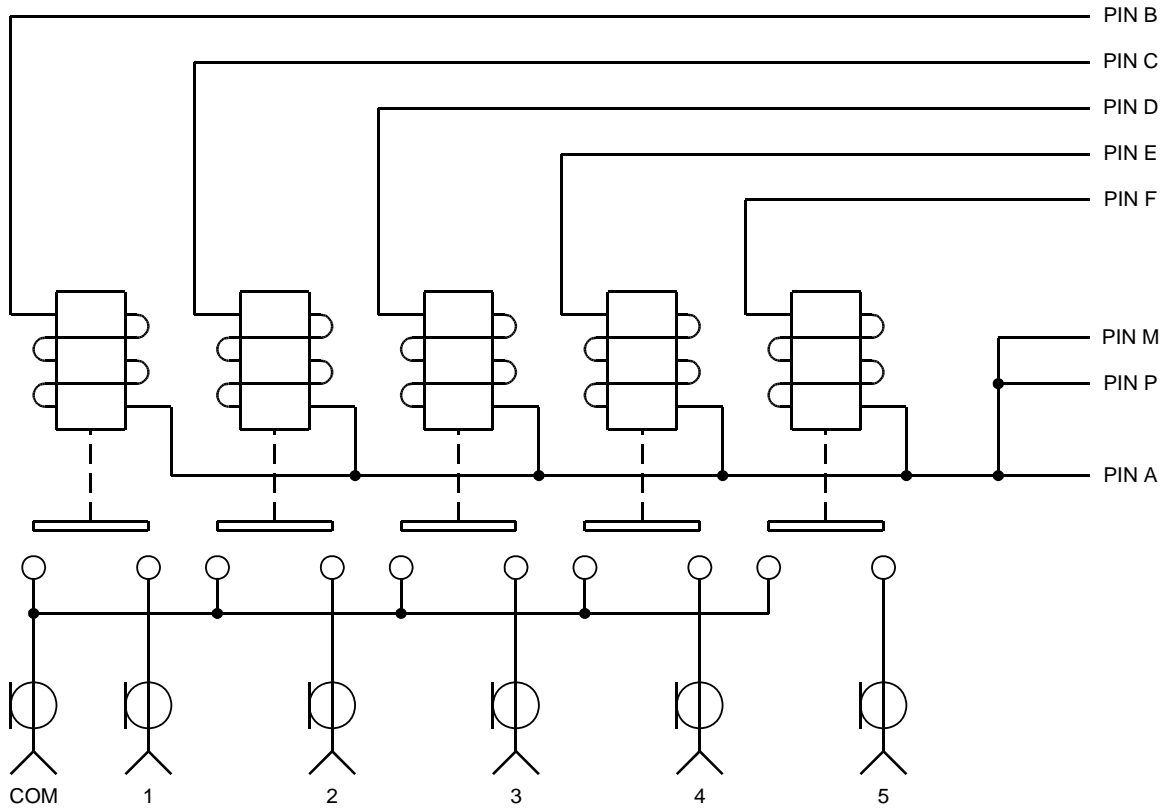

FIGURE 4-6 SM7273 - SP5T

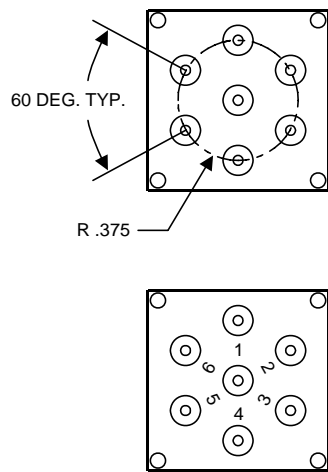
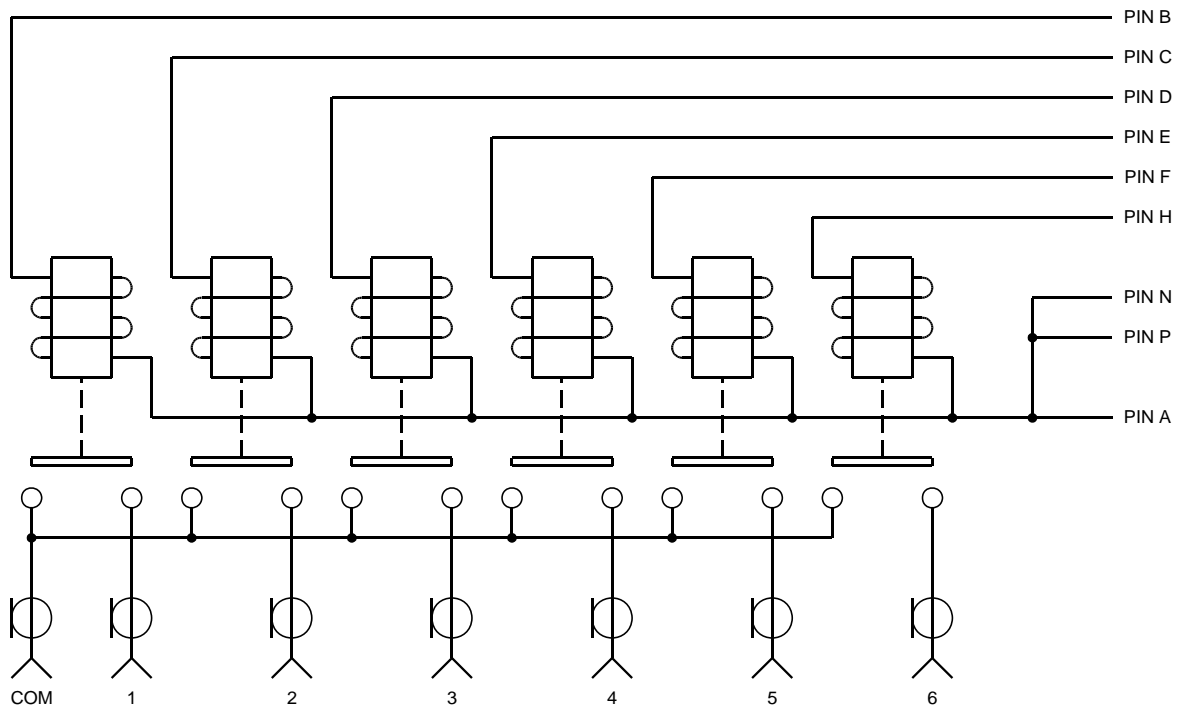

FIGURE 4-7 SM7274 - SP6T

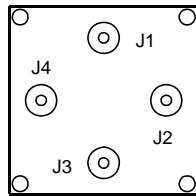
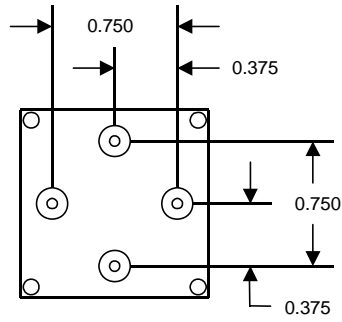
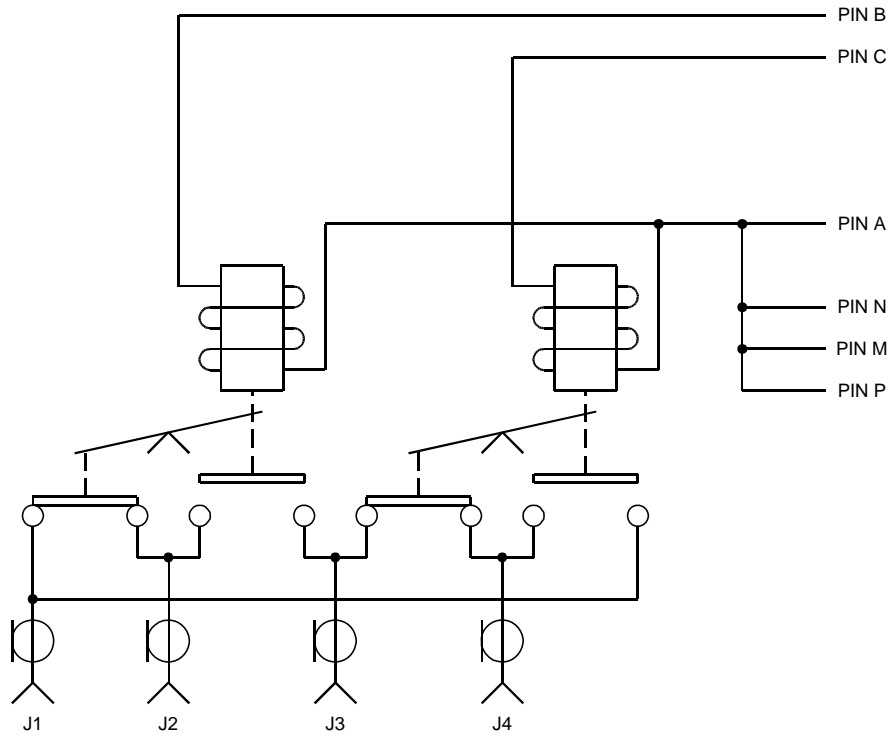

FIGURE 4-8 SM7275 - TRANSFER SWITCH

TABLE 4-3 SM7000 MICROWAVE SWITCH RELAY REGISTER MAP

Offset (Hex)																
12																
10																
E																
C																
A																
8									SW6 ID3	SW6 ID2	SW6 ID1	SW6 ID0	SW5 ID3	SW5 ID2	SW5 ID1	SW5 ID0
6	SW4 ID3	SW4 ID2	SW4 ID1	SW4 ID0	SW3 ID3	SW3 ID2	SW3 ID1	SW3 ID0	SW2 ID3	SW2 ID2	SW2 ID1	SW2 ID0	SW1 ID3	SW1 ID2	SW1 ID1	SW1 ID0
4	K48	K47	K46	K45	K44	K43	K42	K41	K40	K39	K38	K37	K36	K35	K34	K33
2	K32	K31	K30	K29	K28	K27	K26	K25	K24	K23	K22	K21	K20	K19	K18	K17
0	K16	K15	K14	K13	K12	K11	K10	K9	K8	K7	K6	K5	K4	K3	K2	K1

TABLE 4-4 SM7000 SWITCH / RELAY CHART

Switch / ID	Relay
SW1	K1 - K8
SW2	K9 - K16
SW3	K17 - K24
SW4	K25 - K32
SW5	K33 - K40
SW6	K41 - K48

SM7001A CONFIGURATION

FRONT PANEL CONNECTION - SM7001A

As part of the SMIP II family of instruments, the SM7001A can hold a combination of switch options. The following pages list the SM7001A and the switch option relay and connector information.

Figure 4-9 shows the location of the four SP6T switches and the 50-pin Relay Bank connector on the front panel. The designations for each of the SMA connectors on the switches are also shown.

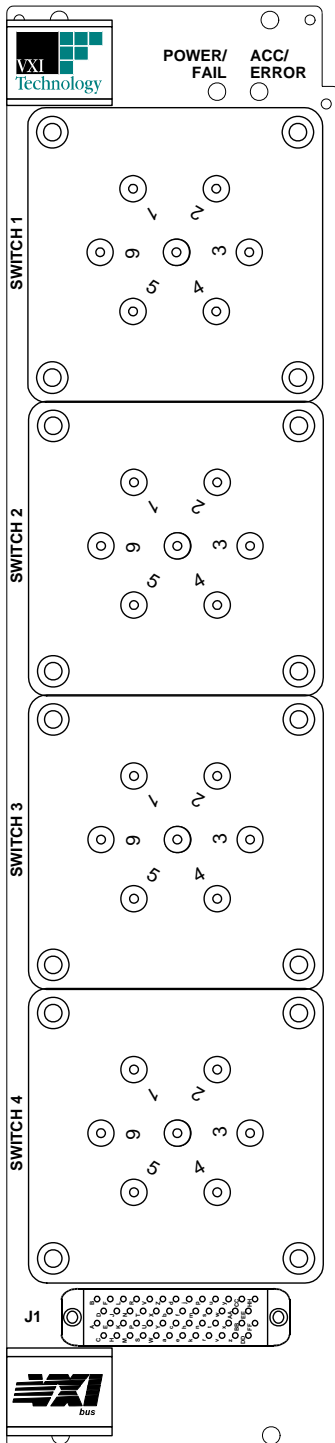

FIGURE 4-9 SM7001A FRONT PANEL

TABLE 4-5 SM7001A CONNECTOR PIN ASSIGNMENTS - INTERFACE TO SMIP II PLATFORM

Pin Number	Description
A	Relay Common (+24 V)
B	K1
C	K2
D	K3
E	K4
F	K5
H	K6
J	K7
K	K8
L	Ground
M	ID0
N	ID1
P	ID2
R	ID3

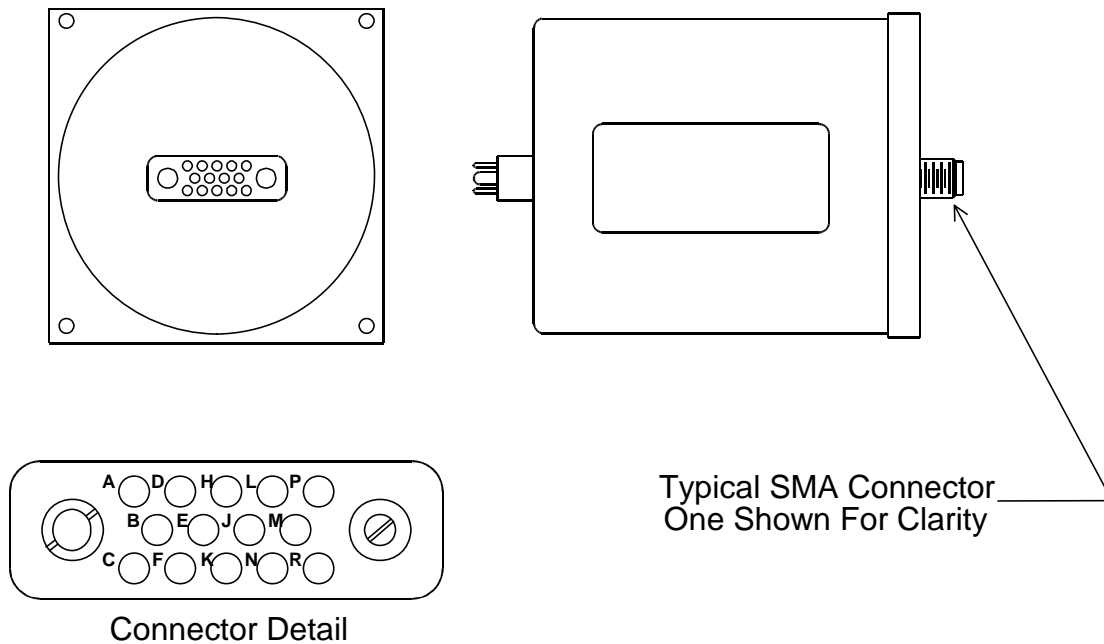

FIGURE 4-10 SWITCH OPTION (SM73XX) TO SM7001A CONNECTION

TABLE 4-6 SM7001A RELAY IDENTIFICATION TABLE

Model DC - 18GHz	Relay Type	ID3	ID2	ID1	ID0	VTI Part No.
SM7374	SP6T Non-Latching	OPEN	COM	COM	OPEN	56-0023-004

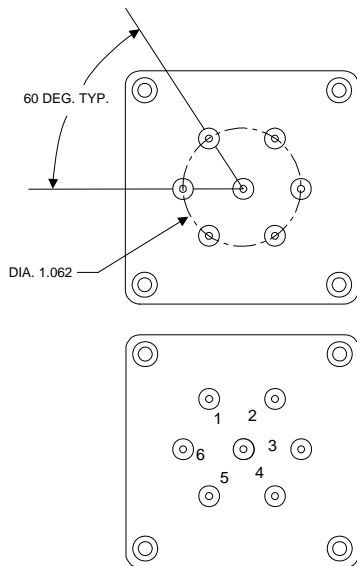
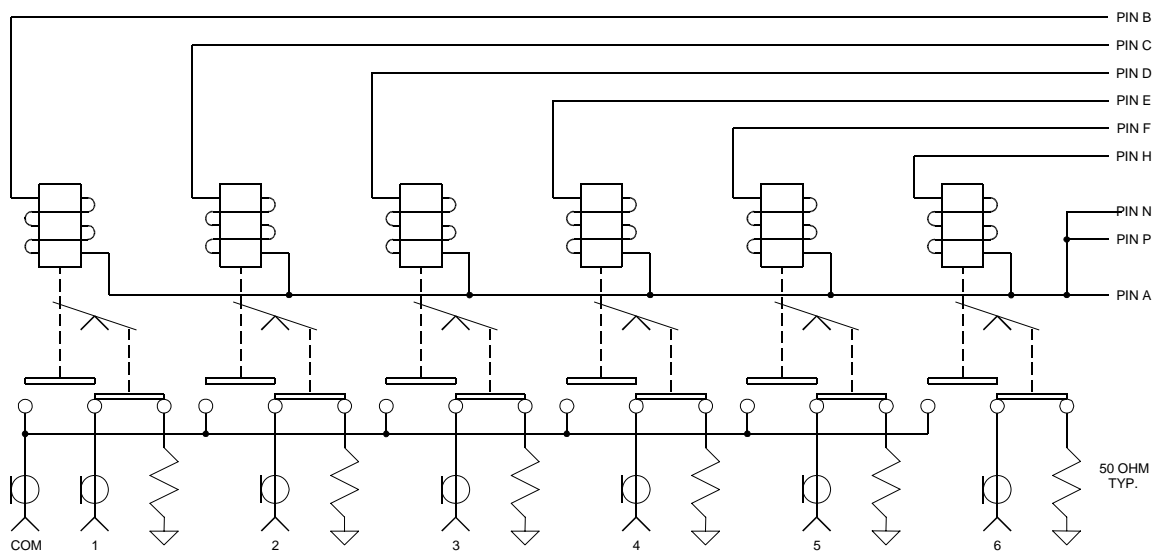

FIGURE 4-11 SM7374 - SP6T

TABLE 4-7 SM7001A MICROWAVE SWITCH RELAY REGISTER MAP

Offset (Hex)																
12																
10																
E																
C																
A																
8									Not Used	Not Used	Not Used	Not Used	Not Used	Not Used	Not Used	Not Used
6	SW4 ID3	SW4 ID2	SW4 ID1	SW4 ID0	SW3 ID3	SW3 ID2	SW3 ID1	SW3 ID0	SW2 ID3	SW2 ID2	SW2 ID1	SW2 ID0	SW1 ID3	SW1 ID2	SW1 ID1	SW1 ID0
4	Not Used	Not Used	Not Used	Not Used	Not Used	Not Used	Not Used	Not Used	Not Used	Not Used	Not Used	Not Used	Not Used	Not Used	Not Used	Not Used
2	K32	K31	K30	K29	K28	K27	K26	K25	K24	K23	K22	K21	K20	K19	K18	K17
0	K16	K15	K14	K13	K12	K11	K10	K9	K8	K7	K6	K5	K4	K3	K2	K1

TABLE 4-8 SM7001A SWITCH / RELAY CHART

Switch / ID	Relay
SW1	K1 - K8
SW2	K9 - K16
SW3	K17 - K24
SW4	K25 - K32

SM7001L CONFIGURATION

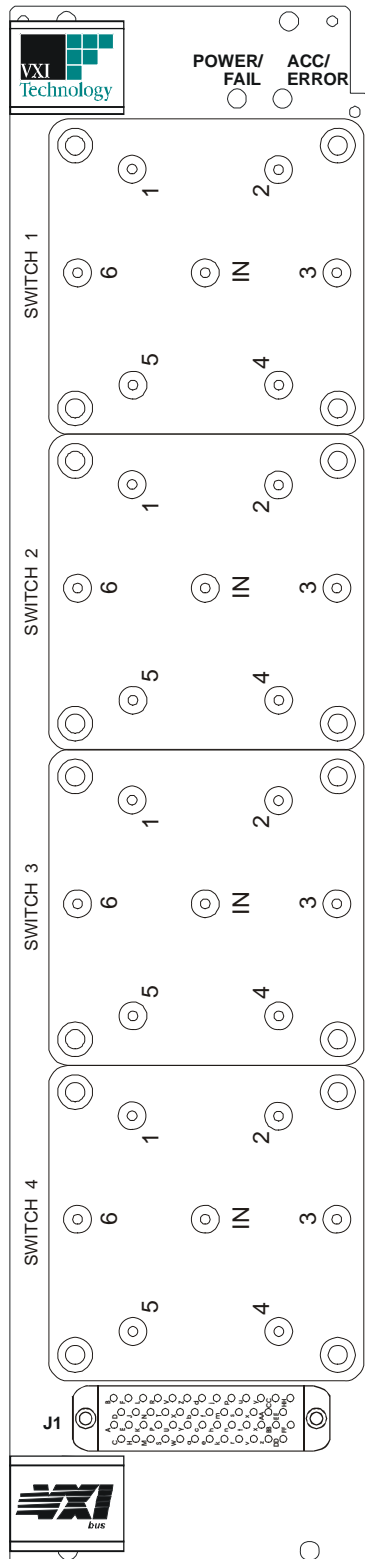

FRONT PANEL CONNECTION - SM7001L

The SM7001L is part of the SMIP II family, offering the extensive control and interfacing features provided by SMIP II. Microwave relay technology has been pioneered to offer density, modularity and cost benefits.

The SM7001L base unit can house up to 4 microwave 20 GHz latching, self-terminated multi-position relays. In order to drive additional RF/Microwave components, such as attenuators, 32 SPST relays (non-latching) are also provided per SM7001L.

Each SPDT relay includes isolated indicator circuitry, allowing the status of the relays to be read directly via the VXI backplane. Even after power is cycled, this allows users to determine the relay position.

The SM7001L can be easily modified to house alternative microwave building blocks (i.e. terminated SPDT relays or 1 x 4s) and controlled using the same instrument drivers and control logic found throughout the SMIP II family. Since the combination of relays is vast, not all configurations have been listed.

The 7374L relays are “pluggable” from the front, allowing them to be easily replaced for maintainability. They may be purchased separately for configuration growth during integration.

Figure 4-12 shows the location of the four latching SP6T switches and the 50-pin Relay Bank connector on the front panel. The designations for each of the SMA connectors on the switches are also shown.

FIGURE 4-12 SM7001L FRONT PANEL

SWITCH MODULE INSTALLATION

Adding and removing switch modules from the SM7001L is done via software. A menu exists in the soft front panel that configures the SM7001L baseboard for a change in configuration. To add or remove a switch module, power down the module, add/remove the switch module(s), then power up the module and use the soft front panel menu to configure the baseboard. Unlike the SM7001A, the SM7001L switch modules do not have configurable relay IDs.

SWITCH MODULE OPERATION



The latching relays in the microwave switches used in the SM7001L are controlled by pulsing the coil drives, thereby minimizing power consumption. The coils are driven active for the time delay period set in the Delay Register. The user should be careful to set the Delay Register with the proper value for the microwave switch modules installed in the SM7001L. ***Unreliable relay operation may occur if the proper coil drive time is not set.*** See the description of the *Delay Register* for more details on its timeout period.

When setting a channel on an SM7001L microwave switch module, the module always clears the last set channel before setting the newly selected channel. If a previously set channel is set for a second time, then the switch will experience a break and then a re-make of the selected channel.

During a Power Off event, the channel last set in the microwave switch module will not be cleared. For this reason, it is important to have the relays set to a known state before a Power Off event. If a channel was being programmed during the Power Off event, then the state of the microwave switch may be ambiguous. If this occurs, reprogram the channels as desired after the instrument is powered on.

Read back of the microwave switch state is accomplished by using a spare contact for each relay in the switch module. This mode of read back provides the most reliable state information of the latching relays in the switch module by actually providing mechanical throw information.

TABLE 4-9 SM7001L CONNECTOR PIN ASSIGNMENTS - INTERFACE TO SMIP II PLATFORM

Pin Number	Description
1	Relay Common (+24 V)
2	Reset
3	K1
4	K2
5	K3
6	K4
7	K5
8	K6
9	Unused
10	Read Back K1
11	Read Back K2
12	Read Back K3
13	Read Back K4
14	Read Back K5
15	Read Back K6

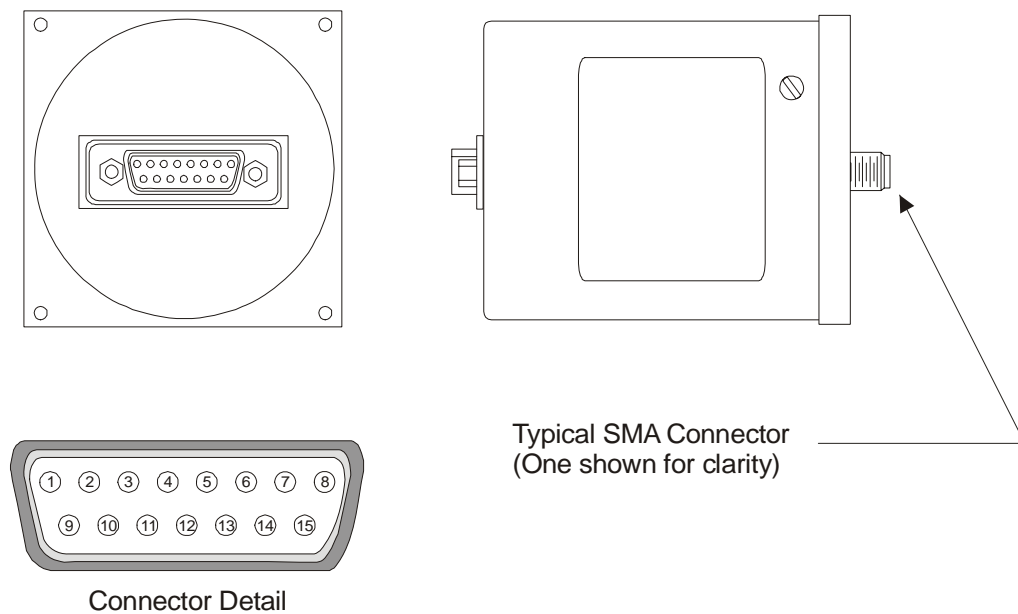

FIGURE 4-13 SWITCH OPTION (SM7374L) TO SM7001L CONNECTION

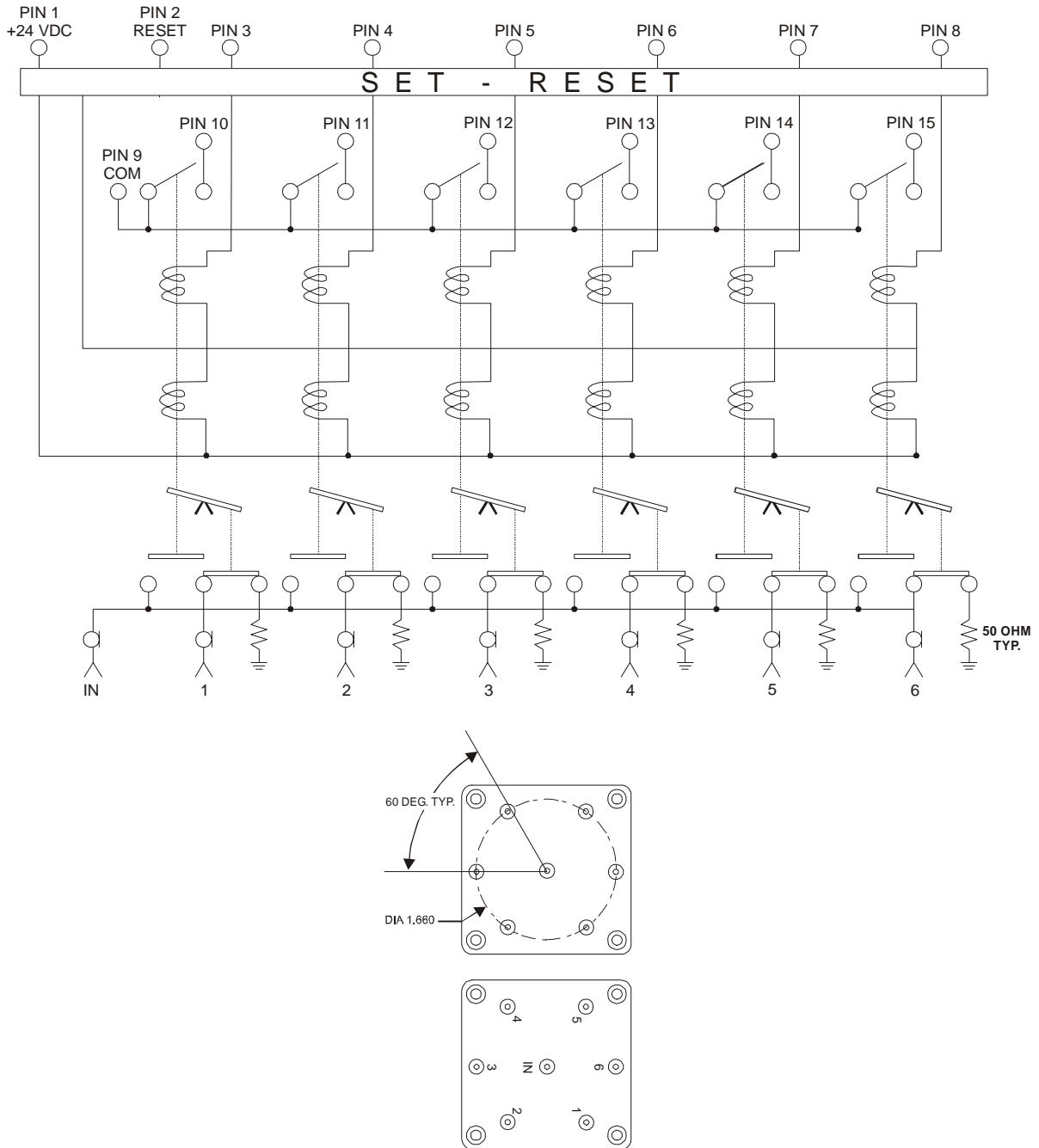

FIGURE 4-14 SM7374L - SP6T

TABLE 4-10 SM7001L MICROWAVE SWITCH RELAY REGISTER MAP

Offset (Hex)																
12																
10																
E																
C																
A																
8									K30 RB	K29 RB	K28 RB	K27 RB	K26 RB	K25 RB	K22 RB	K21 RB
6	K20 RB	K19 RB	K18 RB	K17 RB	K14 RB	K13 RB	K12 RB	K11 RB	K10 RB	K9 RB	K6 RB	K5 RB	K4 RB	K3 RB	K2 RB	K1 RB
4	Not Used	Not Used	Not Used	Not Used	Not Used	Not Used	Not Used	Not Used	Not Used	Not Used	Not Used	Not Used	Not Used	Not Used	Not Used	Not Used
2	K32 RST		K30	K29	K28	K27	K26	K25	K24 RST		K22	K21	K20	K19	K18	K17
0	K16 RST		K14	K13	K12	K11	K10	K9	K8 RST		K6	K5	K4	K3	K2	K1

Note: RST = Reset, RB = Read-back

TABLE 4-11 SM7001L SWITCH / RELAY CHART

Switch / ID	Relay
SW1	K1 - K8 K1 RB - K6 RB
SW2	K9 - K16 K9 RB - K14 RB
SW3	K17 - K24 K17 RB - K22 RB
SW4	K25 - K32 K25 RB - K30 RB

SM7002 CONFIGURATION

FRONT PANEL CONNECTION - SM7002

The SM7002 offers a 40 GHz switch module version of the SM7001A. The SM7002 functions the same as the SM7001A base unit with the 32-channel relay drivers. The difference is the 1 x 6 switch-modules are hard-wired into the unit. Figure 4-15 shows the front panel and connector locations. The SM7002 options are:

SM7002-1	One 1 x 6 switch module installed
SM7002-2	Two 1 x 6 switch modules installed
SM7002-3	Three 1 x 6 switch modules installed
SM7002-4	Four 1 x 6 switch modules installed

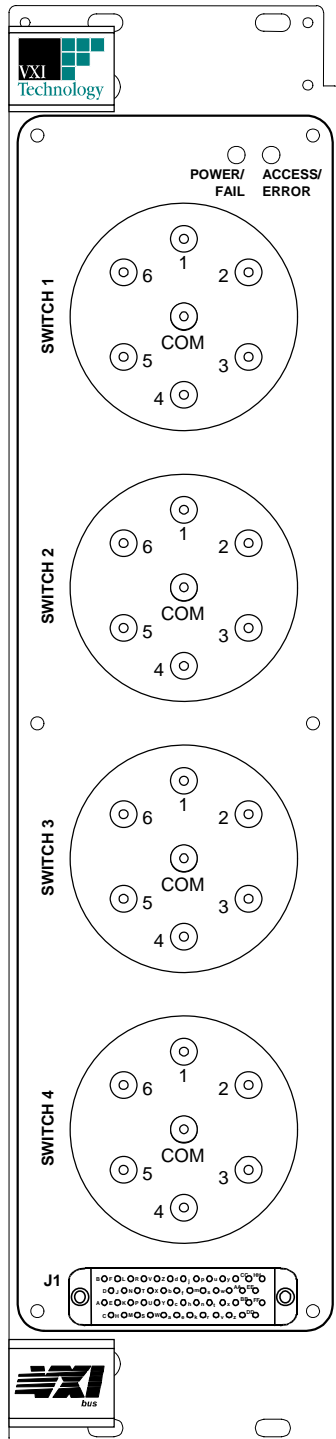

FIGURE 4-15 SM7002 FRONT PANEL

TABLE 4-12 SM7002 MICROWAVE SWITCH RELAY REGISTER MAP

Offset (Hex)																
12																
10																
E																
C																
A																
8									Not Used	Not Used	Not Used	Not Used	Not Used	Not Used	Not Used	Not Used
6	SW4 ID3	SW4 ID2	SW4 ID1	SW4 ID0	SW3 ID3	SW3 ID2	SW3 ID1	SW3 ID0	SW2 ID3	SW2 ID2	SW2 ID1	SW2 ID0	SW1 ID3	SW1 ID2	SW1 ID1	SW1 ID0
4	Not Used	Not Used	Not Used	Not Used	Not Used	Not Used	Not Used	Not Used	Not Used	Not Used	Not Used	Not Used	Not Used	Not Used	Not Used	Not Used
2	K32	K31	K30	K29	K28	K27	K26	K25	K24	K23	K22	K21	K20	K19	K18	K17
0	K16	K15	K14	K13	K12	K11	K10	K9	K8	K7	K6	K5	K4	K3	K2	K1

TABLE 4-13 SM7002 SWITCH / RELAY CHART

Switch / ID	Relay
SW1	K1 - K8
SW2	K9 - K16
SW3	K17 - K24
SW4	K25 - K32

SM7012L CONFIGURATION

FRONT PANEL CONNECTION - SM7012L

The SM7012L is part of the SMIP II family, offering the extensive control and interfacing features provided by SMIP II. Microwave relay technology has been pioneered to offer density, modularity and cost benefits.

The SM7012L houses 12 microwave 20 GHz latching, self-terminated SPDT relays. In order to drive additional RF/Microwave components, such as attenuators, 32 SPST relays (non-latching) are also provided per SM7012L.

Each SPDT relay includes isolated indicator circuitry, allowing the status of the relays to be read directly via the VXI backplane, even after power is cycled, this allows users to determine the relay position.

For applications where a small mixture of self-terminated SPDT and multi-position switches are needed, refer to the SM7013L and SM7016L modules.

Figure 4-16 shows the location of the twelve latching SPDT switch modules (SW1 through SW12) along with the 50-pin Relay Bank connector on the front panel (J1). The designations for each of the SMA connectors on the switches are also shown. Note that this is a fixed configuration module, as the relays are hard-wired into the unit.

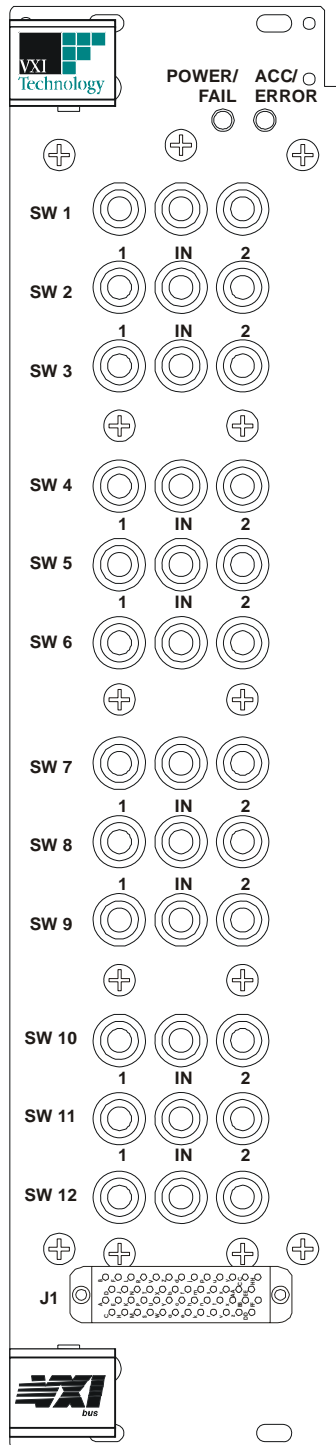

FIGURE 4-16 SM7012L FRONT PANEL

SWITCH MODULE OPERATION



The latching relays in the microwave switches used in the SM7012L are controlled by pulsing the coil drives, thereby minimizing power consumption. The coils are driven active for the time delay period set in the Delay Register. The user should be careful to set the Delay Register with the proper value for the microwave switch modules installed in the SM7012L. ***Unreliable relay operation may occur if the proper coil drive time is not set.*** See the description of the *Delay Register* for more details on its timeout period.

When setting a channel on an SM7012L microwave switch module, the module always clears the last set channel before setting the newly selected channel. If a previously set channel is set for a second time, then the switch will experience a break and then a re-make of the selected channel.

During a Power Off event, the channel last set in the microwave switch module will not be cleared. For this reason, it is important to have the relays set to a known state before a Power Off event. If a channel was being programmed during the Power Off event, then the state of the microwave switch may be ambiguous. If this occurs, reprogram the channels as desired after the instrument is powered on.

Read back of the microwave switch state is accomplished by using a spare contact for each relay in the switch module. This mode of read back provides the most reliable state information of the latching relays in the switch module by actually providing mechanical throw information.

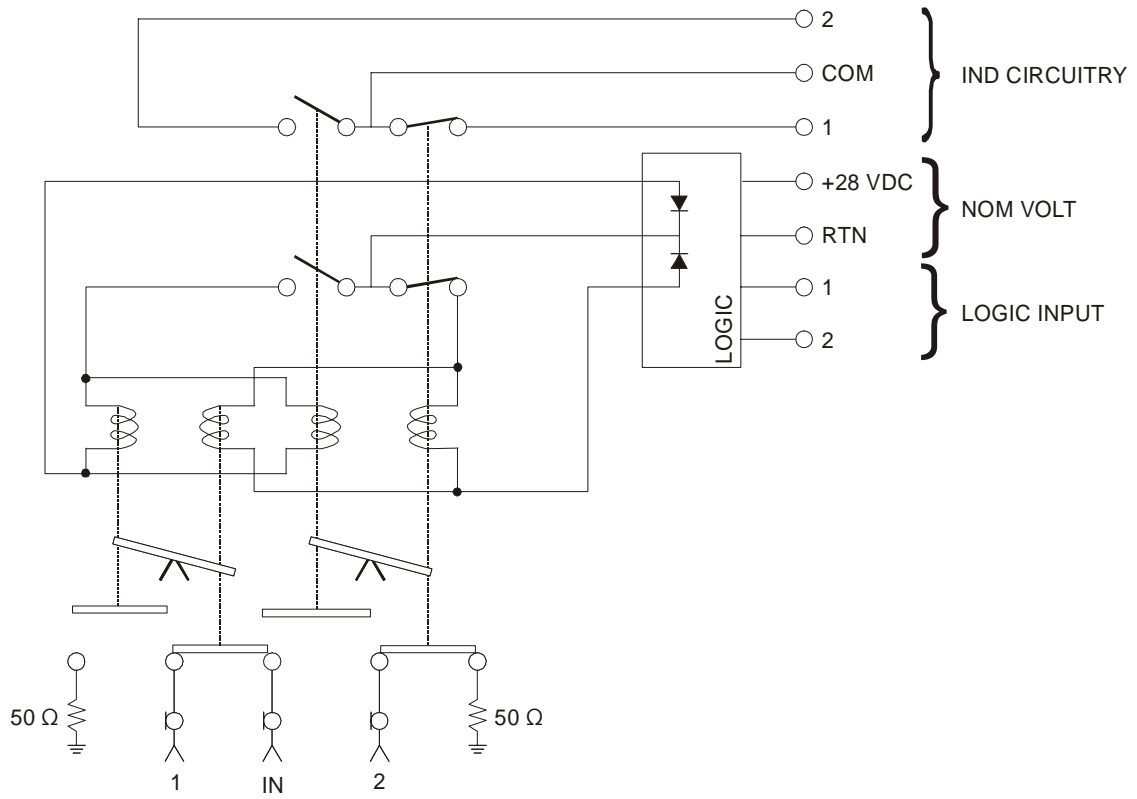

FIGURE 4-17 SPDT SWITCH SCHEMATIC

TABLE 4-14 SM7012L MICROWAVE SWITCH RELAY REGISTER MAP

Offset (Hex)																
12																
10																
E																
C																
A																
8									K24 RB	K23 RB	K22 RB	K21 RB	K20 RB	K19 RB	K18 RB	K17 RB
6	K16 RB	K15 RB	K14 RB	K13 RB	K12 RB	K11 RB	K10 RB	K9 RB	K8 RB	K7 RB	K6 RB	K5 RB	K4 RB	K3 RB	K2 RB	K1 RB
4	Not Used	Not Used	Not Used	Not Used	Not Used	Not Used	Not Used	Not Used	Not Used	Not Used	Not Used	Not Used	Not Used	Not Used	Not Used	Not Used
2			K24	K23	K22	K21	K20	K19			K18	K17	K16	K15	K14	K13
0			K12	K11	K10	K9	K8	K7			K6	K5	K4	K3	K2	K1

Note: RB = Read-back

TABLE 4-15 SM7012L SWITCH / RELAY CHART

Switch / ID	Relay
SW1	K1, K2 K1 RB, K2 RB
SW2	K3, K4 K3 RB, K4 RB
SW3	K5, K6 K5 RB, K6 RB
SW4	K7, K8 K7 RB, K8 RB
SW5	K9, K10 K9 RB, K10 RB
SW6	K11, K12 K11 RB, K12 RB
SW7	K13, K14 K13 RB, K14 RB
SW8	K15, K16 K15 RB, K16 RB
SW9	K17, K18 K17 RB, K18 RB
SW10	K19, K20 K19 RB, K20 RB
SW11	K21, K22 K21 RB, K22 RB
SW12	K23, K24 K23 RB, K24 RB

SM7013L CONFIGURATION

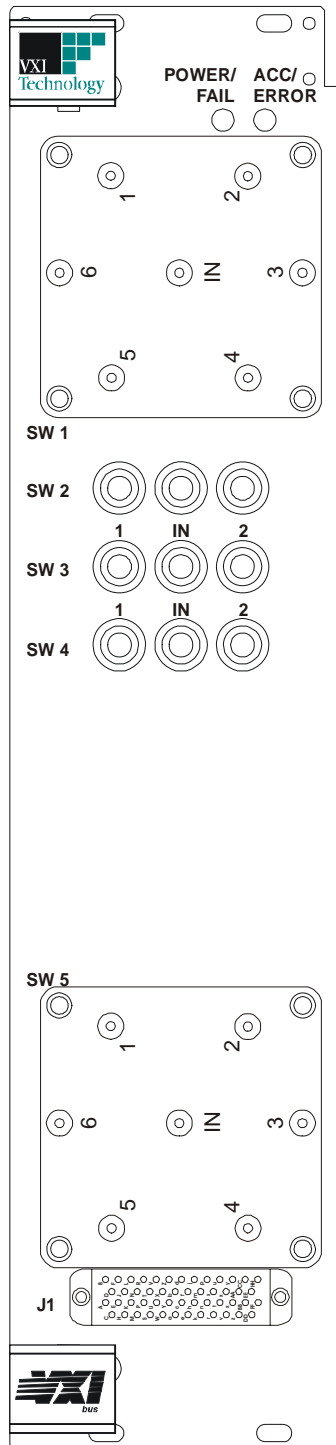

FRONT PANEL CONNECTION - SM7013L

The SM7013L is part of the SMIP II family, offering the extensive control and interfacing features provided by SMIP II. Microwave relay technology has been pioneered to offer density, modularity and cost benefits.

The SM7013L houses three microwave 20 GHz latching, self-terminated SPDT relays and has the option of adding up to two SP6T 20 GHz latching, self-terminated switches. In order to drive additional RF/Microwave components, such as attenuators, 32 SPST relays (non-latching) are also provided per SM7013L.

Each switch includes isolated indicator circuitry, allowing the status of the relays to be read directly via the VXI backplane, even after power is cycled, this allows users to determine the relay position.

For applications where a higher mixture of self-terminated SPDT and multi-position switches are needed, the SM7001L and SM7012L modules are recommended.

Figure 4-18 shows the location of the three latching SPDT switch modules (SW2 through SW4), two installed SP6T switch modules (SW1 and SW5), along with the 50-pin Relay Bank connector on the front panel (J1). The designations for each of the SMA connectors on the switches are also shown. Note that the SPDT switch modules are fixed, as the relays are hard-wired into the unit.

FIGURE 4-18 SM7013L FRONT PANEL

SWITCH MODULE INSTALLATION

Adding and removing switch modules from the SM7013L is done via software. A menu exists in the soft front panel that configures the SM7013L baseboard for a change in configuration. To add or remove a switch module, power down the module, add/remove the switch module(s), then power up the module and use the soft front panel menu to configure the baseboard. Unlike the SM7001A, the SM7013L switch modules do not have configurable relay IDs.

SWITCH MODULE OPERATION



The latching relays in the microwave switches used in the SM7013L are controlled by pulsing the coil drives, thereby minimizing power consumption. The coils are driven active for the time delay period set in the Delay Register. The user should be careful to set the Delay Register with the proper value for the microwave switch modules installed in the SM7013L. ***Unreliable relay operation may occur if the proper coil drive time is not set.*** See the description of the *Delay Register* for more details on its timeout period.

When setting a channel on an SM7013L microwave switch module, the module always clears the last set channel before setting the newly selected channel. If a previously set channel is set for a second time, then the switch will experience a break and then a re-make of the selected channel.

During a Power Off event, the channel last set in the microwave switch module will not be cleared. For this reason, it is important to have the relays set to a known state before a Power Off event. If a channel was being programmed during the Power Off event, then the state of the microwave switch may be ambiguous. If this occurs, reprogram the channels as desired after the instrument is powered on.

Read back of the microwave switch state is accomplished by using a spare contact for each relay in the switch module. This mode of read back provides the most reliable state information of the latching relays in the switch module by actually providing mechanical throw information.

TABLE 4-16 SP6T CONNECTOR PIN ASSIGNMENTS - INTERFACE TO SMIP II PLATFORM

Pin Number	Description
1	Relay Common (+24 V)
2	Reset
3	K1
4	K2
5	K3
6	K4
7	K5
8	K6
9	Unused
10	Read Back K1
11	Read Back K2
12	Read Back K3
13	Read Back K4
14	Read Back K5
15	Read Back K6

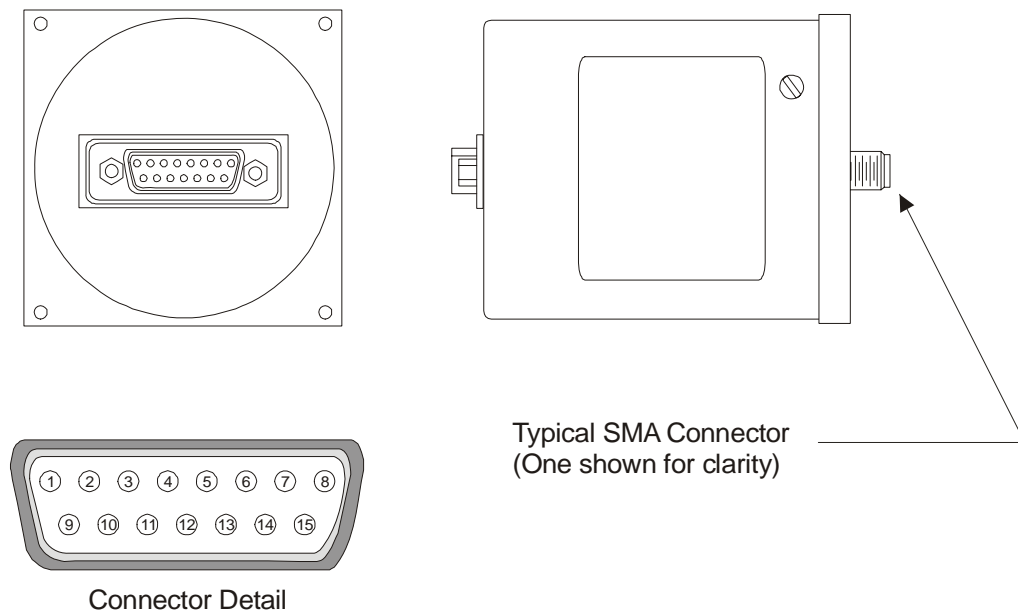

FIGURE 4-19 SWITCH OPTION (SM7374L) TO SM7013L CONNECTION

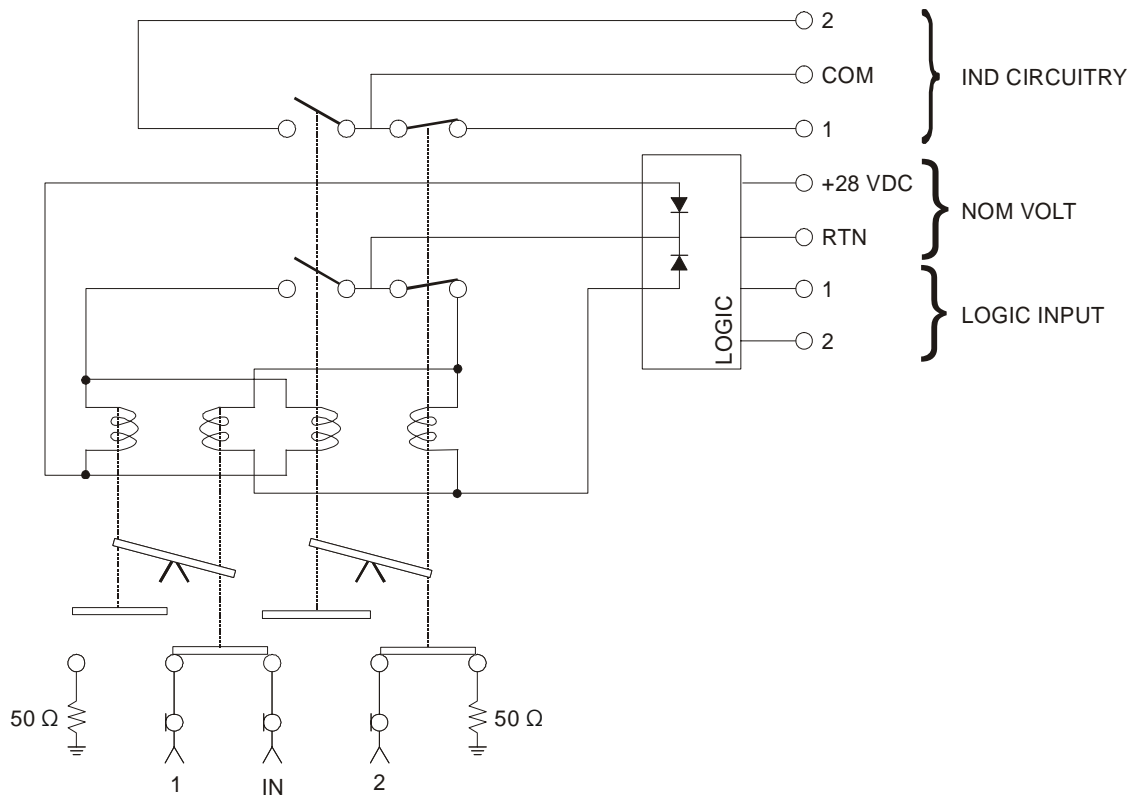

FIGURE 4-20 SPDT SWITCH SCHEMATIC

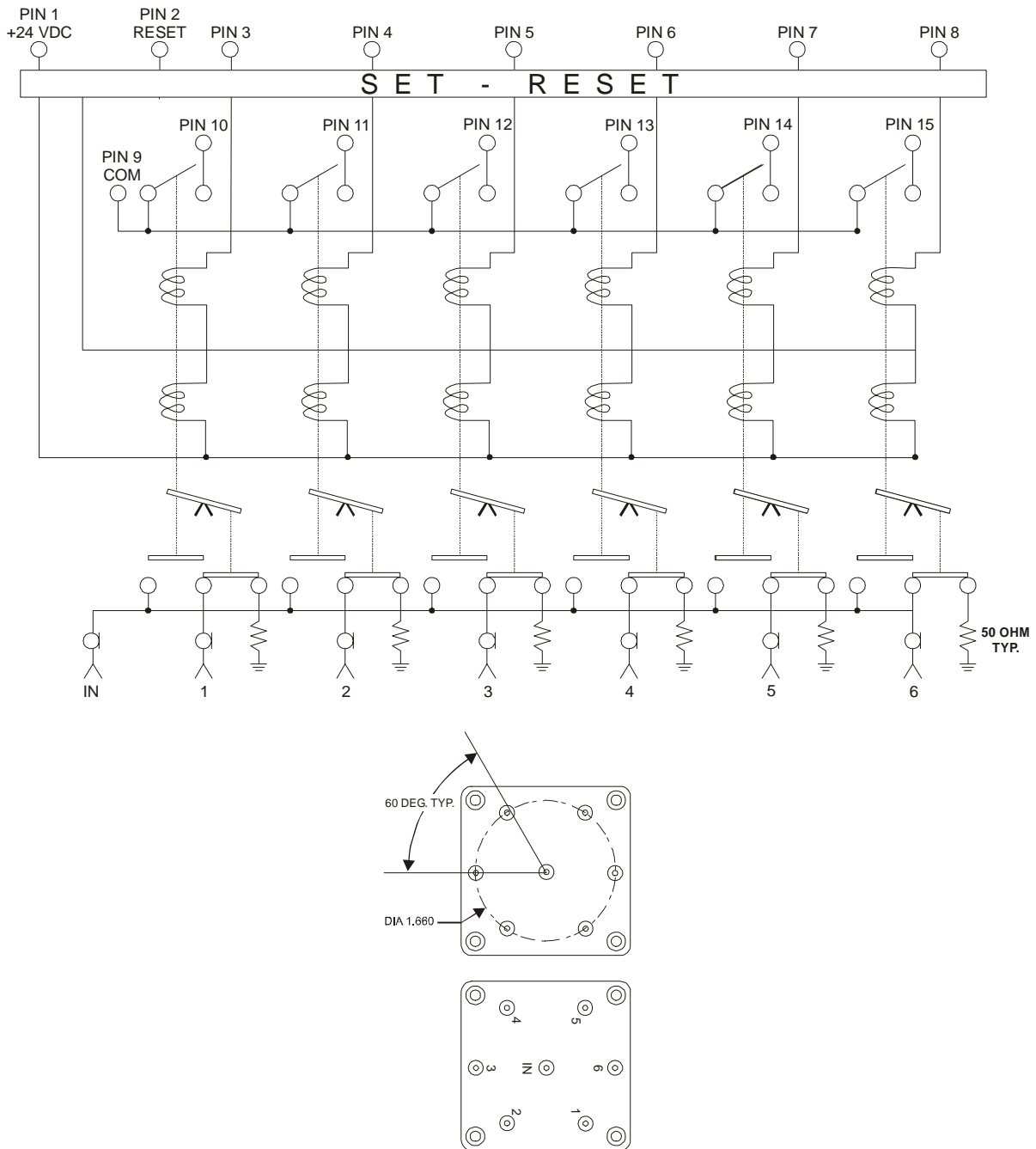

FIGURE 4-21 SM7374L - SP6T

TABLE 4-17 SM7013L MICROWAVE SWITCH RELAY REGISTER MAP

Offset (Hex)																
12																
10																
E																
C																
A																
8															K22 RB	K21 RB
6	K20 RB	K19 RB	K18 RB	K17 RB	K14 RB	K13 RB	K12 RB	K11 RB	K10 RB	K9 RB	K6 RB	K5 RB	K4 RB	K3 RB	K2 RB	K1 RB
4	Not Used	Not Used	Not Used	Not Used	Not Used	Not Used	Not Used	Not Used	Not Used	Not Used	Not Used	Not Used	Not Used	Not Used	Not Used	Not Used
2											K22	K21	K20	K19	K18	K17
0	K16 RST		K14	K13	K12	K11	K10	K9	K8 RST		K6	K5	K4	K3	K2	K1

Note: RST = Reset, RB = Read-back

TABLE 4-18 SWITCH/RELAY CHART

Switch / ID	Relay
SW1	K1 - K8 K1 RB - K6 RB
SW5	K9 - K16 K9 RB - K16 RB
SW2	K17, K18 K17 RB, K18 RB
SW3	K19, K20 K19 RB, K20 RB
SW4	K21, K22 K21 RB, K22 RB

SM7016L CONFIGURATION

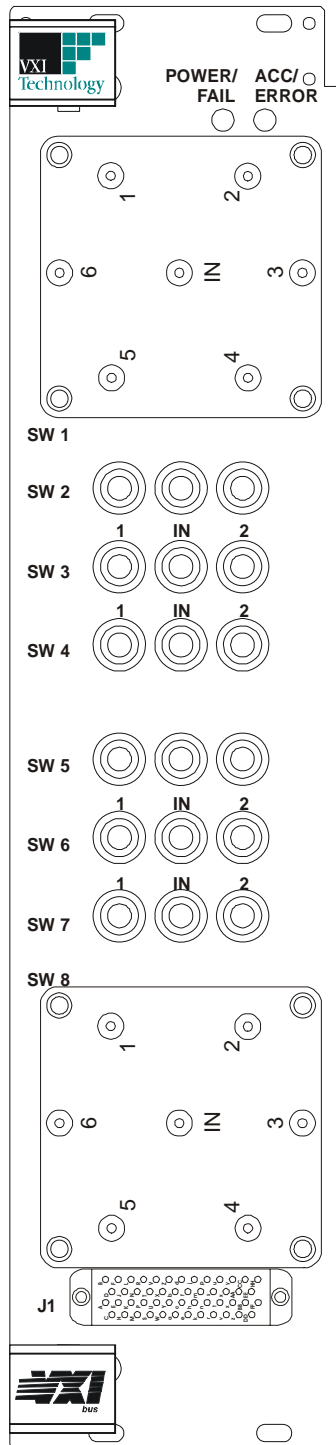

FRONT PANEL CONNECTION - SM7016L

The SM7016L is part of the SMIP II family, offering the extensive control and interfacing features provided by SMIP II. Microwave relay technology has been pioneered to offer density, modularity and cost benefits.

The SM7016L houses six 20 GHz latching, self-terminated SPDT relays and has the option of adding up to two SP6T 20 GHz latching, self-terminated switches. In order to drive additional RF/Microwave components, such as attenuators, 32 SPST relays (non-latching) are also provided per SM7016L.

Each switch includes isolated indicator circuitry, allowing the status of the relays to be read directly via the VXI backplane, even after power is cycled, this allows users to determine the relay position.

For applications where a higher mixture of self-terminated SPDT and multi-position switches are needed, the SM7001L and SM7012L modules are recommended.

Figure 4-22 shows the location of the six latching SPDT switch modules (SW2 through SW7), two installed SP6T switch modules (SW1 and SW8), along with the 50-pin Relay Bank connector on the front panel (J1). The designations for each of the SMA connectors on the switches are also shown. Note that the SPDT switch modules are fixed, as the relays are hard-wired into the unit.

FIGURE 4-22 SM7016L FRONT PANEL

SWITCH MODULE INSTALLATION

Adding and removing switch modules from the SM7016L is done via software. A menu exists in the soft front panel that configures the SM7016L baseboard for a change in configuration. To add or remove a switch module, power down the module, add/remove the switch module(s), then power up the module and use the soft front panel menu to configure the baseboard. Unlike the SM7001A, the SM7016L switch modules do not have configurable relay IDs.

SWITCH MODULE OPERATION



The latching relays in the microwave switches used in the SM7016L are controlled by pulsing the coil drives, thereby minimizing power consumption. The coils are driven active for the time delay period set in the Delay Register. The user should be careful to set the Delay Register with the proper value for the microwave switch modules installed in the SM7016L. ***Unreliable relay operation may occur if the proper coil drive time is not set.*** See the description of the *Delay Register* for more details on its timeout period.

When setting a channel on an SM7016L microwave switch module, the module always clears the last set channel before setting the newly selected channel. If a previously set channel is set for a second time, then the switch will experience a break and then a re-make of the selected channel.

During a Power Off event, the channel last set in the microwave switch module will not be cleared. For this reason, it is important to have the relays set to a known state before a Power Off event. If a channel was being programmed during the Power Off event, then the state of the microwave switch may be ambiguous. If this occurs, reprogram the channels as desired after the instrument is powered on.

Read back of the microwave switch state is accomplished by using a spare contact for each relay in the switch module. This mode of read back provides the most reliable state information of the latching relays in the switch module by actually providing mechanical throw information.

TABLE 4-19 SP6T CONNECTOR PIN ASSIGNMENTS - INTERFACE TO SMIP II PLATFORM

Pin Number	Description
1	Relay Common (+24 V)
2	Reset
3	K1
4	K2
5	K3
6	K4
7	K5
8	K6
9	Unused
10	Read Back K1
11	Read Back K2
12	Read Back K3
13	Read Back K4
14	Read Back K5
15	Read Back K6

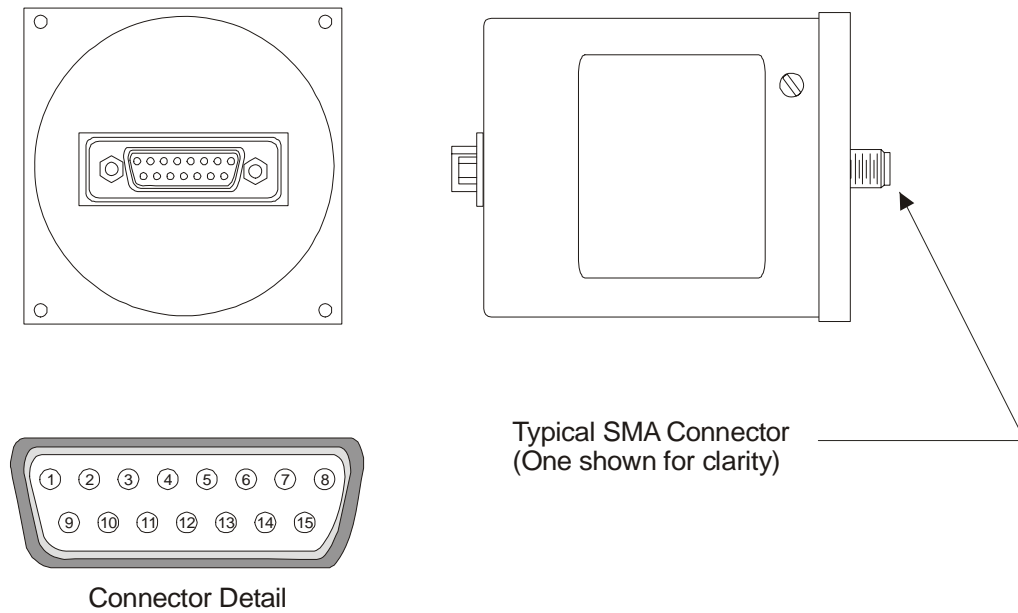

FIGURE 4-23 SWITCH OPTION (SM7374L) TO SM7016L CONNECTION

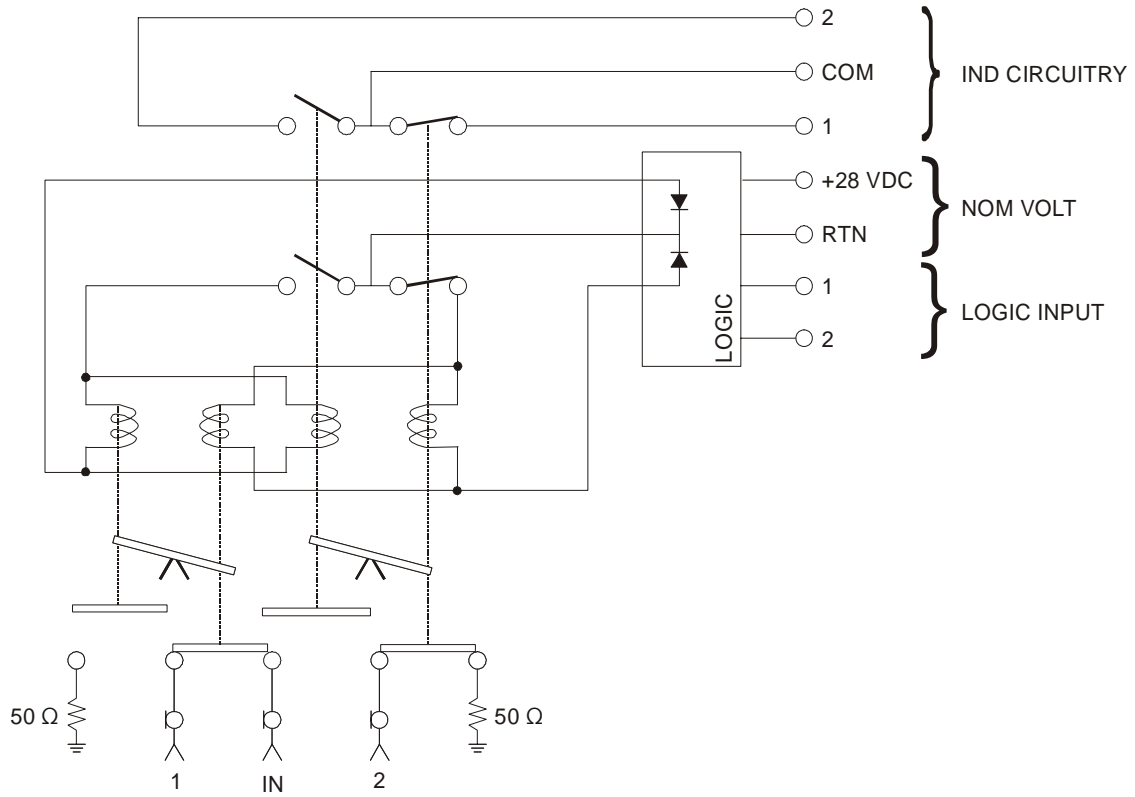

FIGURE 4-24 SPDT SWITCH SCHEMATIC

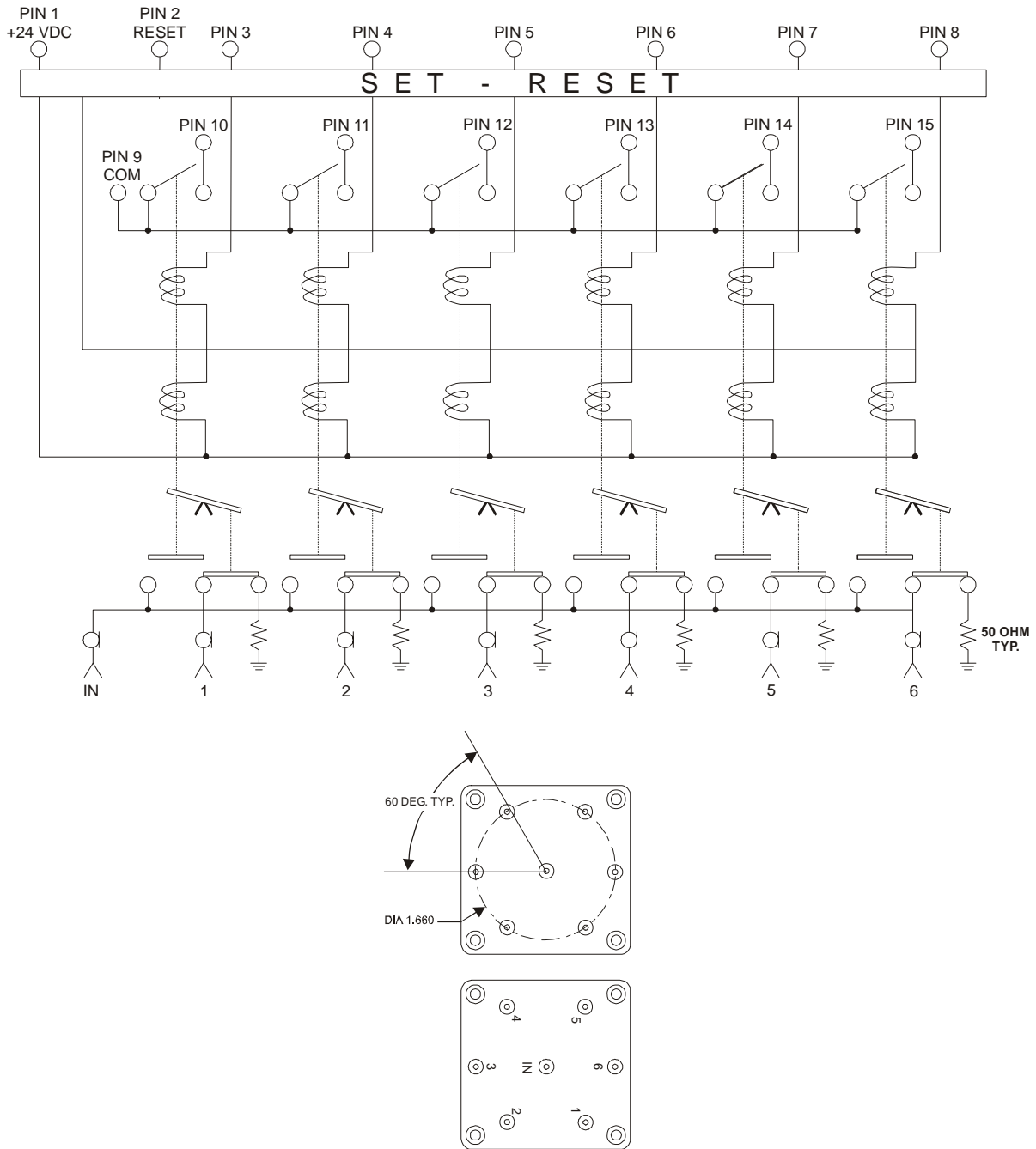

FIGURE 4-25 SM7374L - SP6T

TABLE 4-20 SM7016L MICROWAVE SWITCH RELAY REGISTER MAP

Offset (Hex)																
12																
10																
E																
C																
A																
8									K28 RB	K27 RB	K26 RB	K25 RB	K24 RB	K23 RB	K22 RB	K21 RB
6	K20 RB	K19 RB	K18 RB	K17 RB	K14 RB	K13 RB	K12 RB	K11 RB	K10 RB	K9 RB	K6 RB	K5 RB	K4 RB	K3 RB	K2 RB	K1 RB
4	Not Used	Not Used	Not Used	Not Used	Not Used	Not Used	Not Used	Not Used	Not Used	Not Used	Not Used	Not Used	Not Used	Not Used	Not Used	Not Used
2			K28	K27	K26	K25	K24	K23			K22	K21	K20	K19	K18	K17
0	K16 RST		K14	K13	K12	K11	K10	K9	K8 RST		K6	K5	K4	K3	K2	K1

Note: RST = Reset, RB = Read-back

TABLE 4-21 SWITCH/RELAY CHART

Switch / ID	Relay
SW1	K1 - K8 K1 RB - K6 RB
SW8	K9 - K16 K9 RB - K16 RB
SW2	K17, K18 K17 RB, K18 RB
SW3	K19, K20 K19 RB, K20 RB
SW4	K21, K22 K21 RB, K22 RB
SW5	K23, K24 K23 RB, K24 RB
SW6	K25, K26 K25 RB, K26 RB
SW7	K27, K28 K27 RB, K28 RB

32-CHANNEL RELAY DRIVER

The double-wide, C-size VXI modules (SM7001A/7001L/7012L) have a 50-pin relay bank connector located at J1 on the front panel of the modules. Table 4-16 lists the connector pin assignments. Figure 4-18 shows the pin locations for J1. Figure 4-19 shows a schematic of the relay channels and the voltage-select jumpers.

Each of the two relay banks can be independently configured as a sink or source driver, using either the VXI mainframe or an external supply. See the four example applications at the end of this supplement.

CAUTION Use care when wiring the module to prevent damage to the relay banks.

These modules contain internal protection circuitry. The internal current sourcing and handling capabilities of the module and the mainframe must not be exceeded. Properly interface external loads, especially if they are inductive. If an external supply is used, the external B+ and B- lines MUST be connected to the External B+ and the External Ground pins on J1. Flyback-clamping suppression diodes MUST be connected across any inductive loads. (Switching of AC inductive loads is not recommended.) Figures 4-20 through 4-23 show examples of correct interface methods to the relay banks.

TABLE 4-22 PIN ASSIGNMENTS - J1

Bank A Pin	Function	Relay	Bank B Pin	Function	Relay
A, C, E, H	External B+	-	B, D, F, J	External B+	-
x, y, z	External Ground	-	CC, DD, EE	External Ground	-
AA, BB	External Ground	-	FF, HH	External Ground	-
d	Channel A-0	K1	p	Channel B-0	K17
L	Channel A-1	K2	V	Channel B-1	K18
b	Channel A-2	K3	T	Channel B-2	K19
S	Channel A-3	K4	M	Channel B-3	K20
a	Channel A-4	K5	W	Channel B-4	K21
k	Channel A-5	K6	e	Channel B-5	K22
t	Channel A-6	K7	r	Channel B-6	K23
w	Channel A-7	K8	m	Channel B-7	K24
j	Channel A-8	K9	u	Channel B-8	K25
R	Channel A-9	K10	Z	Channel B-9	K26
X	Channel A-10	K11	N	Channel B-10	K27
P	Channel A-11	K12	K	Channel B-11	K28
Y	Channel A-12	K13	U	Channel B-12	K29
h	Channel A-13	K14	c	Channel B-13	K30
v	Channel A-14	K15	n	Channel B-14	K31
s	Channel A-15	K16	f	Channel B-15	K32

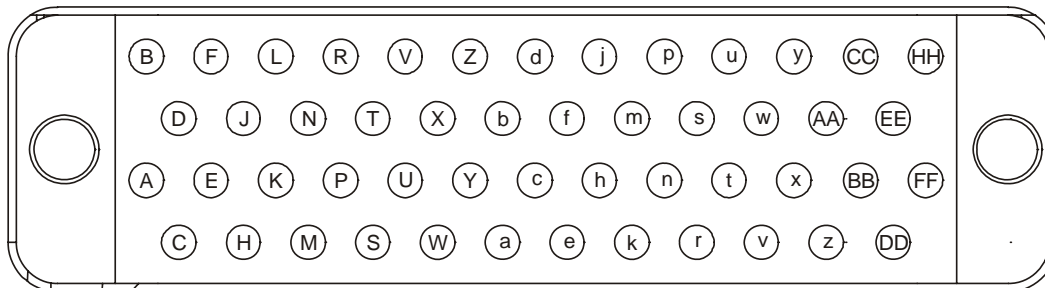

FIGURE 4-26 50-PIN CONNECTOR DETAIL

NOTE Drawing not to scale - pin designations repositioned for legibility.

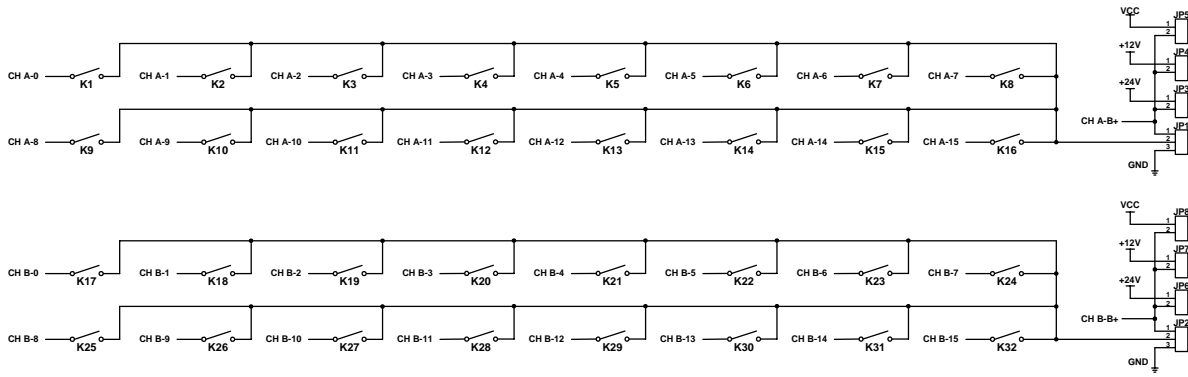

FIGURE 4-27 32 CHANNEL RELAY DRIVER SCHEMATIC

The following relay register map shows the addresses for the 32 relay drivers:

TABLE 4-23 RELAY DRIVER REGISTER MAP

Offset																
406																
404																
402	K32	K31	K30	K29	K28	K27	K26	K25	K24	K23	K22	K21	K20	K19	K18	K17
400	K16	K15	K14	K13	K12	K11	K10	K9	K8	K7	K6	K5	K4	K3	K2	K1

INTERFACE EXAMPLES

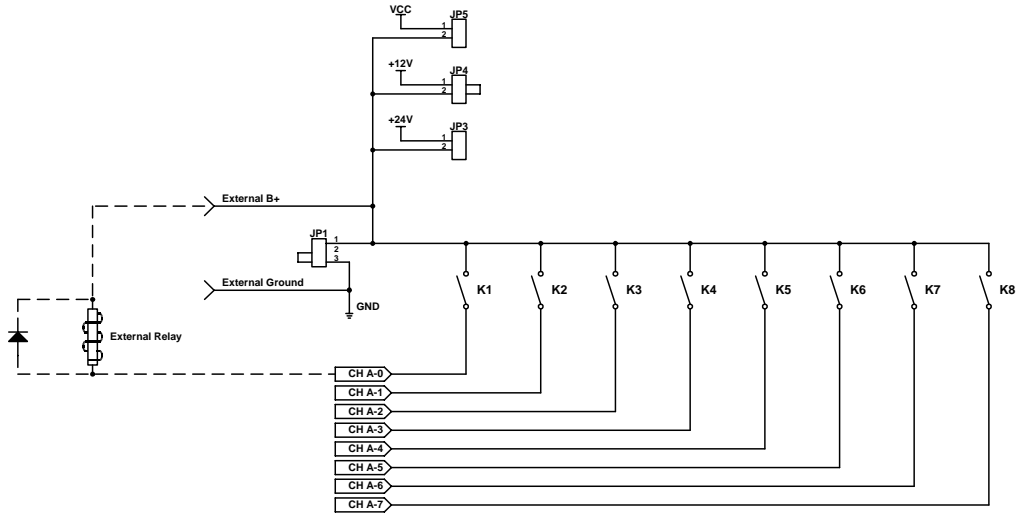

FIGURE 4-28 INTERNAL SUPPLY SINK DRIVER - EXAMPLE

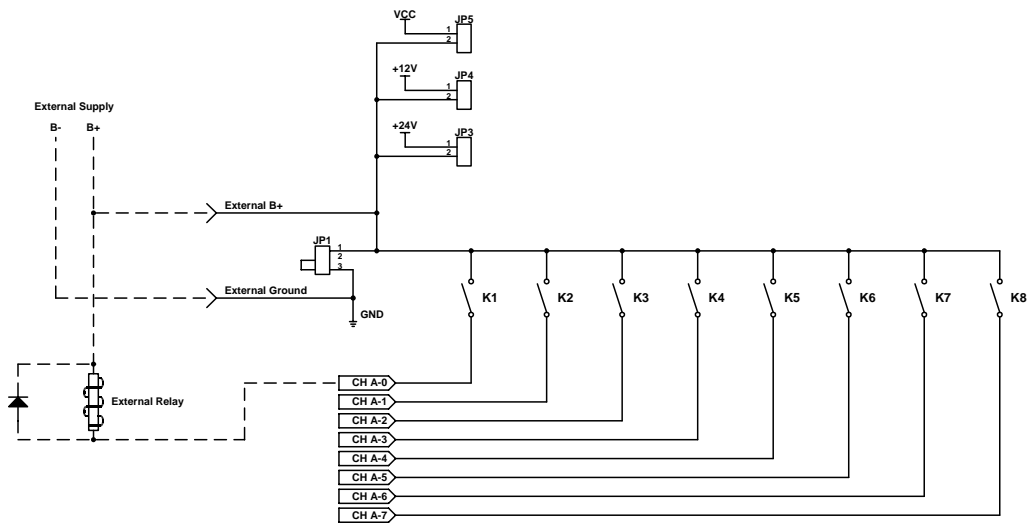

FIGURE 4-29 EXTERNAL SUPPLY SINK DRIVER - EXAMPLE

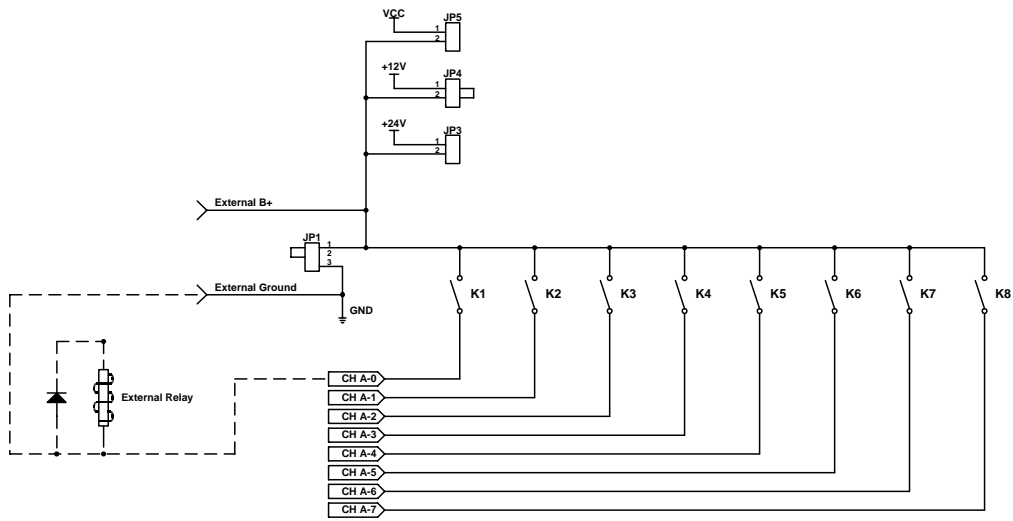

FIGURE 4-30 INTERNAL SUPPLY SOURCE DRIVER - EXAMPLE

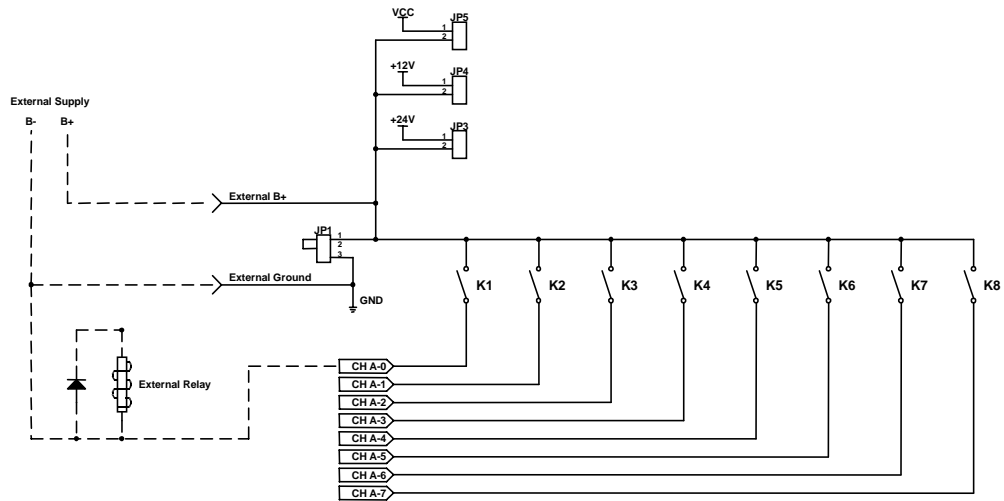

FIGURE 4-31 EXTERNAL SUPPLY SOURCE DRIVER - EXAMPLE

PASS-THROUGH ADAPTERS

INTRODUCTION

The SM72XX and SM73XX pass-through adapters allow the SM7000 and SM7001A modules to control externally mounted relays (option not available on the SM7001L and SM7012L). Each adapter brings eight sinking driver outputs, a common ground and +24 V from the VXI back plane to the front panel. Each output is designed to sink up to 500 mA each and provides inductive fly-back protection. Fly-back protection is provided by an internal 56 V Zener diode from each driver output to ground. Each output uses current flow to sense read back and requires a minimum of 5 mA to flow through the driver to indicate a relay operation. This insures that the driver circuit is operating and all the wiring to the remote relay is intact.

Because the driver is a current sinking type, the external relay may be powered from the provided +24 V or from an external power source. The amount of current the +24 V pin can provide is 500 mA maximum and is protected by a self-healing fuse. The total module current draw for +24 V line must be no greater than 1.5 A. If an external power supply is used, the negative side of the supply must be wired to the ground pin to provide a return current path. The total amount of current flowing through the ground return connection must be no greater than 2.0 A. Because each driver output is protected by a 56 V Zener diode, an externally provided power source should not be greater than 48 A.

TABLE 4-24 SM7000/7001A PASS THROUGH ADAPTERS

Model DC - 18GHz	Relay Type	Base Unit	VTI Part No.
SM7276	Pass-Through Adapter	SM7000	52-0038-000
SM7376	Pass-Through Adapter	SM7001A	52-0069-000

TABLE 4-25 SM7000/7001A PASS-THROUGH ADAPTER CONNECTOR PIN ASSIGNMENTS

Pin Number	Description
A	Relay Common (+24 V)
B	K1
C	K2
D	K3
E	K4
F	K5
H	K6
J	K7
K	K8
L	Ground
M	N/C
N	N/C
P	N/C
R	N/C

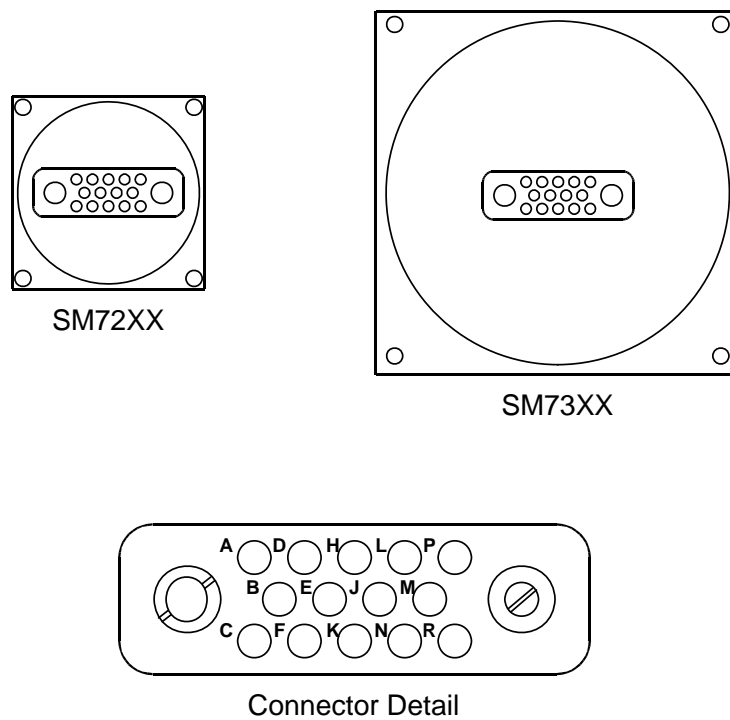
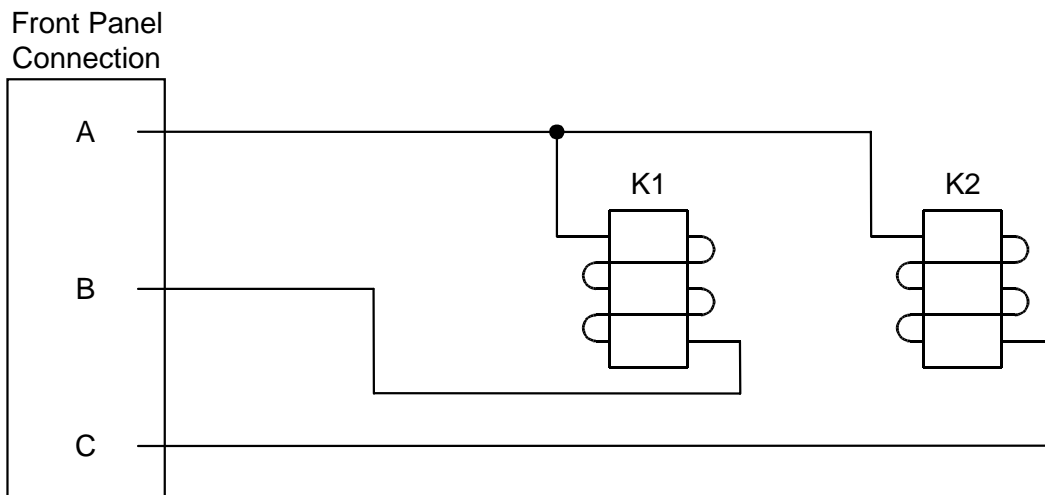

FIGURE 4-32 72XX / 73XX CONNECTOR DETAIL

PASS-THROUGH ADAPTERS - CONNECTION EXAMPLES

The following figures show two examples of using the pass-through adapters. They illustrate wiring external relays both using the internal +24 V power source and using an external source.



Two external relays wired to use the internal +24 volt power

FIGURE 4-33 PASS-THROUGH ADAPTER - RELAY WIRING W/ INTERNAL POWER SOURCE

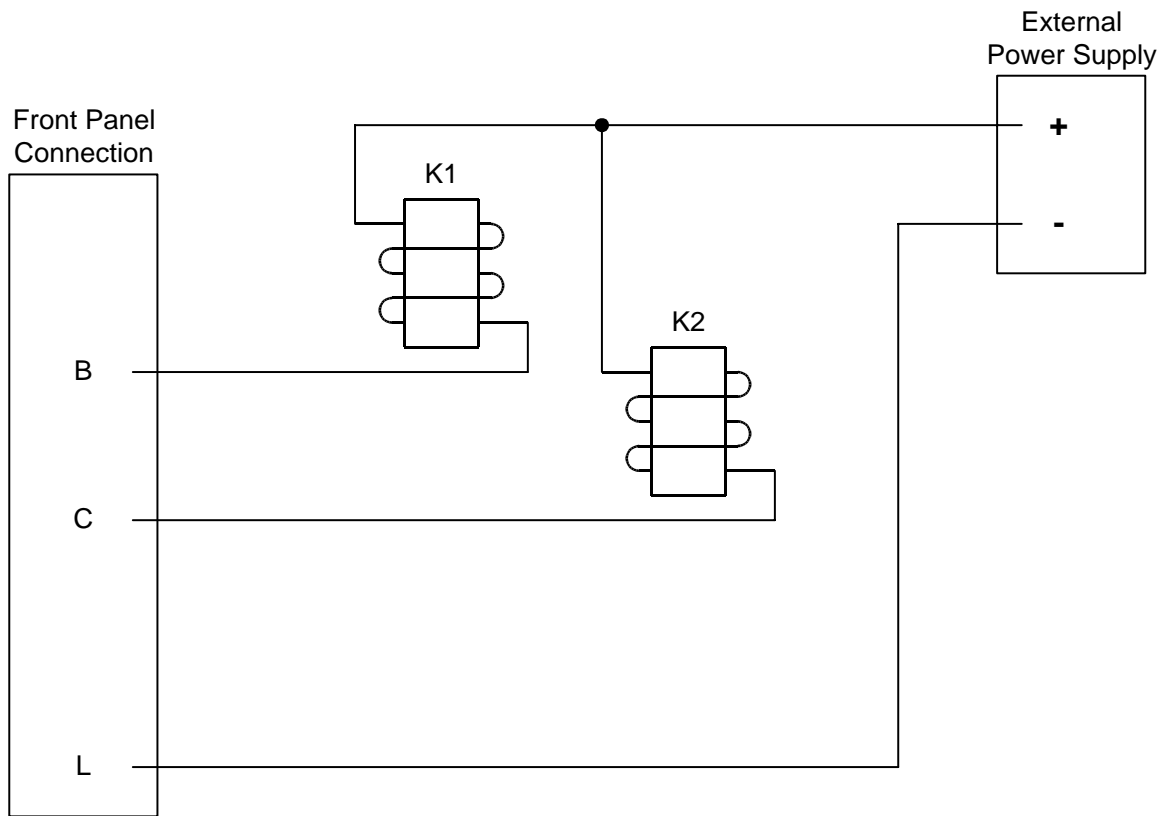

Two external relays wired to use an external power source

FIGURE 4-34 PASS-THROUGH ADAPTER - RELAY WIRING W/ EXTERNAL POWER SOURCE

INDEX

A

A16 address space.....	22
A16 base address	20
A16 offset register	20
A16 offset register address	20
A24 address space.....	20
A24 base address	20
A24/A32 active.....	22
A24/A32 enable.....	23
A24/A32 memory offset	23
A32 address space.....	20
A32 base address	20
Access LED Fail bit.....	32
ACFAILN enable bit	31
address space	17, 22

B

backplane jumpers	15, 16
BBM/MBB bit	32
Break-Before-Make	13

C

cause/status	24
command parsing.....	20
configuration registers	31
cooling	15

D

data bus	34
delay timer	32
device class	22
direct register access.....	13
dynamic configuration	22

E

extended memory device	25
extended memory space.....	17

F

firmware version number	23
Front Panel Open signal operation select bit	33
Front Panel Open signal polarity bit	33
Front Panel Open signal set by this module.....	34

H

handler IRQ line	24
hardware revision code	34

I

IH ENA*	24
interrupt mask	24
interrupter IRQ line	24
IR ENA*	24
IRQ line	24

L

latching relays	11, 31, 55, 62
logical address	15, 16, 17, 22
LSB (<i>least significant bit</i>)	16, 17

M

major hardware version number.....	23
Make-Before-Break.....	13
manufacturer's ID	22
memory space	31
message-based.....	20
minor hardware version number.....	23
model code	22
MODID*	22
module relay address.....	35
MSB (<i>most significant bit</i>)	16, 17

O

offset register.....	20
offset value	20
Openbus Out enable bit	33

P

polled fashion.....	24
power.....	15

R

register address.....	20
register-based device	37
registers	20, 22
relay control	35
Relay Data Read Back polarity bit.....	31
Relay Register address	35
Relay Register offset.....	35
Relay Reset enable bit.....	32
Relay Reset select bit	32
required memory	22
reset	23

S

scan list.....	13
serial clock	25
sysfail inhibit.....	23

V

VISA	37
VXIbus	15, 20
VXIbus extended device	25