

# Easidew I.S.

## Dew-Point Transmitter

(For Hazardous Area Applications)



The Easidew I.S. (intrinsically safe) transmitter is a dew-point transmitter designed and certified for use in hazardous area applications (flammable or explosive gases) in all regions with certification from: IECEx, CSA, FM and ATEX.

The Easidew I.S. is available with a 5/8" UNF process connection or alternatively with a G1/2" BSP or 3/4" UNF process connection. It is designed for ease of use, incorporating all of the features needed to make installation and operation into your air or gas management system as simple as possible.

Michell's Advanced Ceramic Moisture Sensor technology based transmitter is calibrated to international standards and is delivered with a traceable calibration certificate.

### Highlights

- IECEx, CSA, FM, ATEX certified transmitter for use in hazardous areas
- 5/8" UNF, G1/2" BSP or 3/4" UNF process connection
- Dew-point or ppm<sub>v</sub> moisture content
- 2-wire loop powered connection
- Rugged 316 stainless steel IP66 construction
- Measurement range -100 to +20°C
- Accuracy ±2°Cdp
- Calibration Certificate (NPL, NIST)

### Technical Specifications

Performance		
Measurement range	-100 to +20°C dew point	
Accuracy	±2°C dew point	
Response time	5 mins to T95 (dry to wet)	
Repeatability	0.5°C dew point	
Calibration	Traceable 7-point calibration certificate	
Electrical Specifications		
Output signal	4-20 mA (2-wire connection, current source) User configurable over range	
Output	Dew point or moisture content for ppm <sub>v</sub>	
Analog output scaled range	Dew point: -100 to +20°C Moisture content in gas: 0-3000 ppm <sub>v</sub> Non-standard available upon request	
Supply voltage	12 to 28 V DC	
Load resistance	Max 250 Ω @ 12 V (500 Ω @ 24 V)	
Current consumption	20 mA max	
CE marked	Certified	
Operating Specifications		
Operating temperature	-40 to +70°C	
Operating pressure	45 MPa (450 barg) maximum	
Overpressure rating	x2 operating pressure 90 MPa (900 barg)	
Flow rate	1 to 5 NI/min mounted in standard sampling block; 0 to 10m/sec direct insertion	
Temperature coefficient	Temperature compensated across operating temperature range	
Mechanical Specifications		
Ingress protection	IP66 in accordance with standard BS EN 60529:1992, NEMA 4 in protection accordance with standard NEMA 250-2003	
Hazardous area certificates	ATEX: II 1 G Ex ia IIC T4 (-20°C ≤ Ta ≤ +70°C) FM: IS / I / I / ABCD / T4 Ta = +70°C CSA: - IS Class I Div I Groups ABCD T4 IECEx: Ex ia IIC T4 (-20°C ≤ Ta ≤ +70°C)	
Housing material	316 stainless steel	
Dimensions	L=132mm x ø45mm (with connector)	
Filter (sensor protection)	Standard: HDPE Guard <10µm Optional: 316 stainless steel sintered guard <80µm	
Process connection and material	5/8"- 18 UNF Alternatives: G1/2" BSP or 3/4"- 16 UNF 316 stainless steel	
Weight	150g	
Interchangeability	Fully interchangeable transmitter	
Electrical connections	Hirschmann GDS series (DIN 4350-C)	
Diagnostic conditions (factory programmed)	<b>Condition</b>	<b>Output</b>
	Sensor fault	23 mA
	Under-range dew point	4 mA
	Over-range dew point	20 mA
Approved galvanic isolators	KFD2-CR-EX1.20200 KFD2-CR-EX1.30200 KFD0-CS-EX1.50P	KFD0-CS-EX2.50P KFD2-STC4-EX1.H MTL5041 MTL5040

# Easidew I.S.

## Dimensions

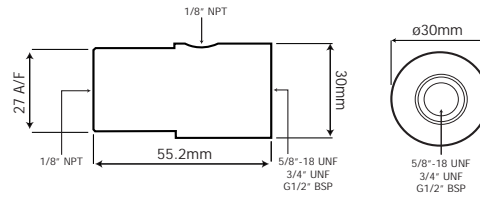
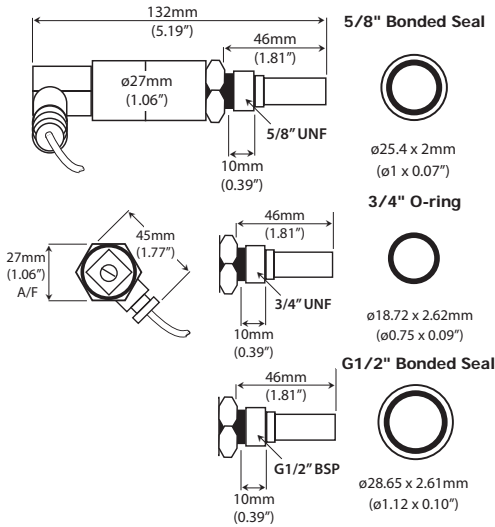

## Electrical Connections

4-20 mA connections 2-wire	
Pin 1	4-20 mA
Pin 3	POWER

## Ordering Codes

To construct the order code, select the relevant feature from the tables below, starting with the base model, which is {Feature A} and then add on options to create a string: {Feature A} + {Feature B} + {Feature C} + {Feature D}

**Order example:** EA2-IS-TX + B1 + C1 + D2  
 Easidew Hazardous Area, 2 wire, 4-20 mA output, G1/2" BSP process connection, -100 to +20°Cdp range, stainless steel sintered guard

Base Model {Feature A}	
Base unit. Easidew Hazardous Area Transmitter 2-wire 4-20 mA	EA2-IS-TX

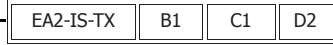

Protection {Feature D}	
Standard HDPE guard (with protection against fine particulate (<10µm))	D1
Stainless steel sintered guard	D2

Range {Feature C}	
-100 to +20°Cdp output range	C1
Non-standard measurement range: v = zero value, w = full scale value, x = unit (C = °Cdp, F = °Fdp, P = ppm <sub>v</sub> ) y = Pressure for ppm, conversion in bar/psig, Z = pressure unit (PG=psig, PA=psia, BG=barg, BA=bara) blank = 0 barg/0 psig	CX(...)

## Accessories and Spare Parts

		Process Connection Size		
		G1/2"	3/4"	5/8"
<b>Sensor Protectors</b>	Pack of 10 replacement HDPE guards for protection against fine particulate <10µm	EA2-HDPE	EA2-HDPE	EA2-HDPE
	Stainless steel sintered guard replacement for protection against fine particulate <80µm	SSG	SSG	SSG
	Pack of 10 particulate filter cartridges for protection against fine particulate <25µm (for Sampler kits)	SSF-PF-10PK		SSF-PF-10PK
<b>Connection Adaptors</b>	3/4" UNF to 5/8" UNF adaptor			APT-PAN
	G 1/2" BSP to 5/8" UNF adaptor			APT-GEI
	1/2" NPT to 5/8" UNF adaptor			APT-TSO
<b>Sampling Blocks</b>	G1/2" 316 stainless steel sample block (with 1/8" NPT inlet & outlet ports)	SB-12		
	G1/2" 316 stainless steel sample block with filter (with 1/8" BSP & 1/4" BSP ports)	A000351		
	3/4" 316 stainless steel sample block with (1/8" NPT inlet & outlet ports)		SB-34	
	5/8" 316 stainless steel sample block (with 1/8" NPT inlet & outlet ports)			CSB
	5/8" Sampler kit – For atmospheric or pressure dp measurements (145 psig / 10 barg max)			EA2-SAM
	5/8" HP (high pressure) Sampler kit – For atmospheric or pressure dp measurements (2900 psig / 200 barg max)			EA2-SAM-HP
<b>Other Parts</b>	KFD0-CS-EX1.50P galvanic isolator (for Easidew I.S. - Pepperl & Fuchs)	GI-PF-01	GI-PF-01	GI-PF-01
	PTFE sample tube – 6mm outside diameter, thick-walled (for Sampler kit) (if more than the standard 0.5mm is required)	PTFE-xx		PTFE-xx
	Cable – 0.8m with mini-DIN mating socket (for NON I.S. sensors)	EA2-CAB-08	EA2-CAB-08	EA2-CAB-08
	Additional cable – total length (if more than the standard 0.8m is required)	EA2-CAB-xx	EA2-CAB-xx	EA2-CAB-xx
	Additional/replacement transmitter labels - 2 labels	GEN-LABEL	GEN-LABEL	GEN-LABEL
	O-rings/Bonded seals for process connection – 5 seals	BS-12-PK5	OR-34-PK5	BS-58-PK5
	Sensor connector	EA2-SC	EA2-SC	EA2-SC
	Communications kit for Easidew I.S.	EA2-CK	EA2-CK	EA2-CK