

USB - Torque Sensor with Configuration and Evaluation Software**DR-3000**

- Nominal torque from 0.1 N·m ... 5000 N·m
- Accuracy class optional 0.05% f. scale
- Feed-in from USB, without ext. power supply
- Speed up to 30,000 min⁻¹
- Up to 2500 Measurements/s per Measuring Channel
- Very short axial length
- Reliable and durable
- Special versions on request
- Suited for mobile operation with a notebook
- Calibration parameter lodged in sensor
- Calibration control actuation by software
- Integrated speed/angle measurement
- Virtually no influence of the bearing friction on the measuring signal
- Power computation by software
- High torsional stiffness
- Simple handling and assembly

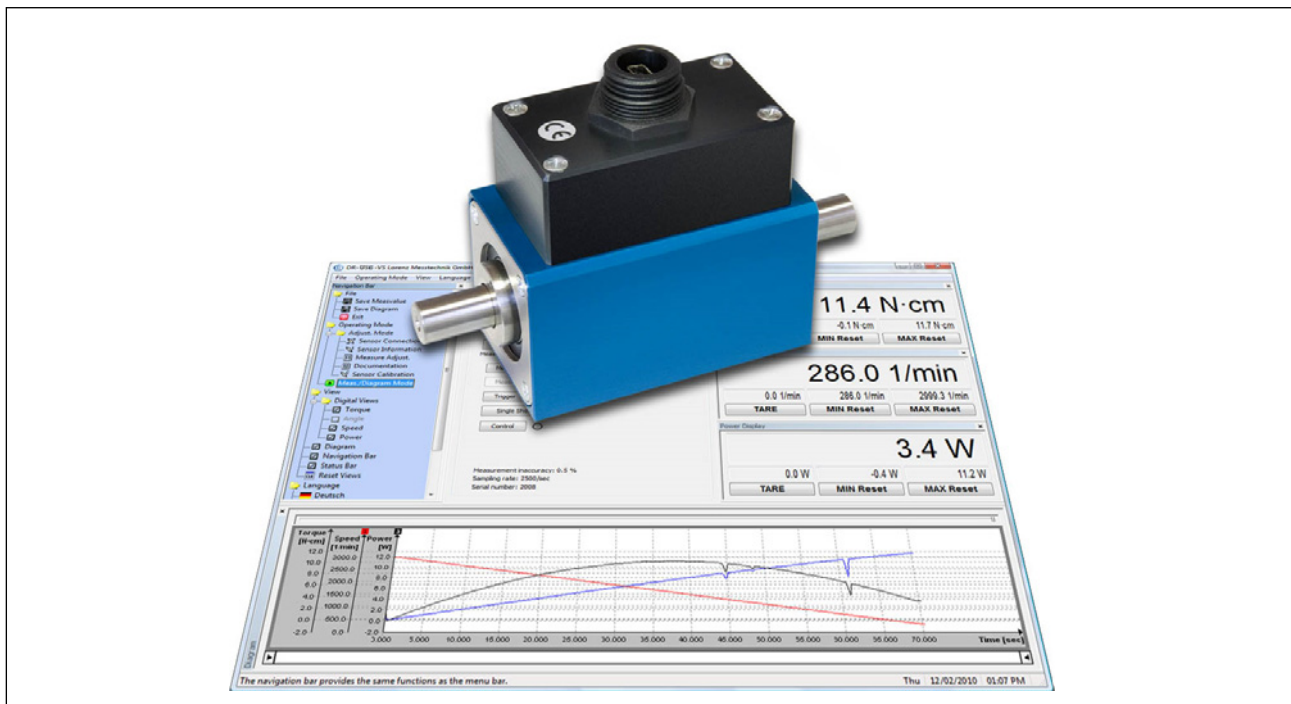

This sensor has a contactless and digital signal transmission from rotor to stator, which means no signal falsification and maintenance-free.

Specifications

Article-No.	Nominal Torque [N·m]	Limit Speed [min ⁻¹]	Springrate [N·m/rad]	Mass Moment of Inertia [kg·m ²]		Limit Thrust Load [N] ¹	Limit Shear Force [N] ²
				Drive Side	Test Side		
114357	0.1	30000	1.8E+01	9.2E-06	2.5E-07	43	1.5
114358	0.2	30000	1.8E+01	9.2E-06	2.5E-07	58	2
111231	0.5	30000	9.4E+01	9.2E-06	2.5E-07	240	3
111177	1	30000	9.4E+01	9.2E-06	2.5E-07	240	3
111232	2	30000	3.7E+02	9.2E-06	2.5E-07	480	7
111233	5	30000	7.7E+02	9.2E-06	2.6E-07	900	16.5
111234	10	30000	8.8E+02	9.3E-06	3.4E-07	1050	21
111235	20	20000	5.1E+03	1.2E-04	6.8E-06	2300	44
111236	30	20000	5.1E+03	1.2E-04	6.8E-06	2300	44
111114	50	20000	9.6E+03	1.2E-04	7.4E-06	5000	142
111237	100	20000	9.6E+03	1.2E-04	7.4E-06	5000	142
111238	200	15000	8.9E+04	5.4E-04	4.4E-04	10000	275
110554	500	15000	1.3E+05	5.4E-04	4.4E-04	13000	400
111240	1000	15000	1.7E+05	6.4E-04	5.3E-04	20000	920
112801	2000	12000	6.3E+05	5.7E-03	5.1E-03	34000	1250
112803	5000	12000	9.6E+05	5.8E-03	5.2E-03	64000	2900

DR-3000		
Accuracy class torque	% f. s.	0.1
Speed resolution	min ⁻¹	1
Speed accuracy	% f. s.	±1
Angle of rotation resolution	degree	0.25
Repeatability (DIN 1319)	%	±0.02
Feed-in from USB	VDC	4 ... 6
Current consumption	mA	≤250
Output signal torque	digits	±25,000
Output signal speed/ angle of rotation	digits	±32,511
Control signal excitation		per Software
Sample rate	kSample/s	2.5
Reference temperature	°C	23
Nominal temperature range	°C	5 ... 45
Service temperature range	°C	0 ... 60
Storage temperature range	°C	-10 ... 70
Temperature coefficient of sensitivity	% f. s./K	±0.01
Temperature coefficient of zero signal	% f. s./K	±0.02
Service torque (static)	% f. s.	150
Limit torque (static)	% f. s.	200
Ultimate torque (static)	% f. s.	>300
Bandwidth (DIN 50 100)	%	70 (peak - peak)
Level of protection (DIN EN 60529)		IP50
Electrical connection		PX0446 IP68 B Mini USB, incl. 3 m connection cable to PC

¹ Unsupported shaft

² Unsupported shaft

Options/ Accessories

Article-No.	Description	% f. s.	
101695	Accuracy class		0.05
	Keys according DIN 6885		on request

Option Calibrations

Article-No.	Description	Steps	Norm
400676	Linearity diagram	25%	Factory standard
400664	Linearity diagram	10%	
400961	Proprietary calibration	3	VDI/VDE 2646
400700	Proprietary calibration	5	
400688	Proprietary calibration	8	
	DAkKS- Calibration		on request

Dimensions

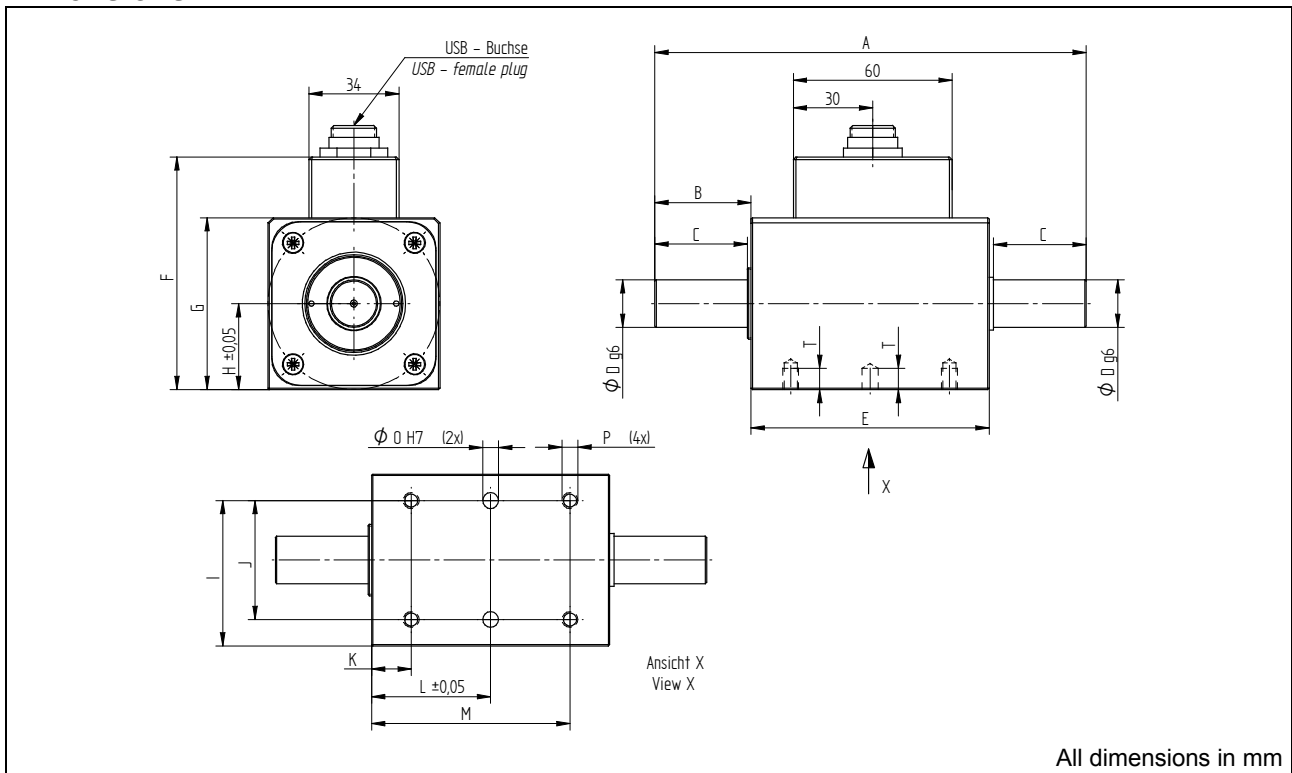

Nominal Torque [N·m]	Dimensions [mm]															
	A	B	C	Ø D	E	F	G	H	I	J	K	L	M	O	P	T
0.1 / 0.2 / 0.5 / 1 / 2 / 5	110	19	17	8	71	63	40	20	35	30	12	35.5	59	4	M4	8
10	110	19	17	10	71	63	40	20	35	30	12	35.5	59	4	M4	8
20 / 30 / 50 / 100	163	36.5	35	18	90	88	65	32.5	55	45	15	45	75	6	M6	8
200 / 500	234	56.5	55	32	120	118	95	47.5	82.5	70	20	60	100	8	M8	14
1000	234	56.5	55	42	120	118	95	47.5	82.5	70	20	60	100	8	M8	14
2000 / 5000	372	114	110	70	144	163	140	70	120	100	25	72	119	12	M12	20

Configuration and Evaluation Software

DR-USB-VS

- Convenient configuration and evaluation software
- Graphic presentation of torque/ speed/ power or torque/ angle of rotation
- Automatic scaling of y-axis
- Simultaneous storage of up to 3 physical values
- Automatic storage function of the measured values as CSV- or BMP-File

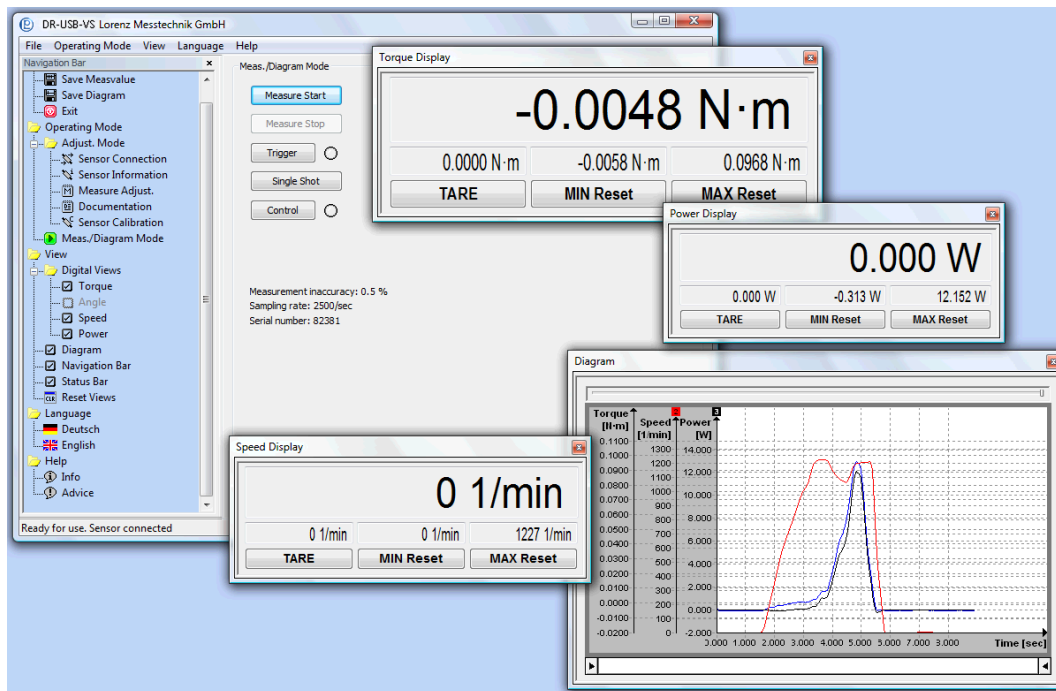

Description

Configuration and evaluation software for easy analysis and graphic presentation on a PC.

The software allows direct read in of measured data into a text file in CSV-Format through the USB-Port of a PC. This enables further analyses with a commercially available spreadsheet program at any time.

Specifications

Type	DR-USB-VS
Interface	USB
Protocol	Lorenz standard protocol
System Requirements	Windows® '03/ '08/ Vista/ 7/ 8 32/64 Bit ³ Dual-Core ex 1.8 GHz (with diagram)

Conversion in physical values	✓
Simultaneous measuring	1 Sensor
Graphic presentation of a physical value	✓
Automatic or manual storage in a CSV and BMP file	✓
Mathematical computation of the mechanical power	✓
Calibration function	✓
Resettable minimum value memory for each measured value	✓
Resettable maximum value memory for each measured value	✓
Variable average determination	✓
Tare for each measured value	✓

³ Windows® is either a registered brand or brand of the Microsoft Corporation in the USA and/or other countries.

All trademarks or brands used in this document refer only to the respective product or the holder of the trademark or brand. Lorenz Messtechnik GmbH does not raise claims to other than their own trademarks or brands.